

## Push Button Control of Digital Potentiometers (DP) with an Increment/Decrement Interface

*Chuck Wojslaw, Director of Applications Engineering*

There are a number of ways of programming digital potentiometers. The best technique depends on the DP's type of interface and its application.

This Design Note discusses the push button control of DP which have an increment/decrement interface in applications where there is no embedded processor. Instead, the DP is programmed using push button switches to generate the control signals for the UP/DN, INC, and CS inputs. For those applications where the programming of the DP is an ongoing requirement, the push button switches and the interface circuitry will be part of the application. For those applications where the DP will be programmed only once during production testing, the switches and their interface will be in an external controller unit. The controller unit containing the push button switches is typically connected to the DP using pins, cable and a connector or a bed-of-nails test system.

The circuit in Figure 1 is a low cost, low component count implementation of a push button controller. A SPST UP/DN switch programs the direction of the pot's wiper, and two momentary contact SPDT, INCR and STORE, switches program the increment and store functions. The momentary contact switches are debounced.

The INCR switch enables a low frequency clock which advances the wiper one position every falling edge of the clock. The clock is enabled as long as the INCR switch is held down and its frequency is roughly determined by  $f \approx 1/R_1C_1$ . A resistor of 200kΩ and a capacitor of 0.33μF produces a measured clock frequency of 17Hz. The oscillator requires a NAND gate with Schmitt-trigger inputs (74HC132 type).

The STORE switch initiates a positive pulse to the chip select line. On the leading edge of this pulse, the current wiper setting of the potentiometer is stored to nonvolatile memory. The pulse width is derived from the  $R_2$  and  $C_2$  differentiator and is roughly determined by  $PW \approx 1/R_2C_2$ . A resistor of 20kΩ and a capacitor of 0.001μF produces a measured pulse width of 18μsec.

$R_3$ ,  $R_4$  and  $R_5$  are the pulldown and pullup resistors for the increment, chip select, and up/down DP inputs. For 'program once' applications, all input control signals must have either pullup or pulldown resistors when the programmer is disconnected. The values of the pullup and pulldown resistors are in the 5-50kΩ range.

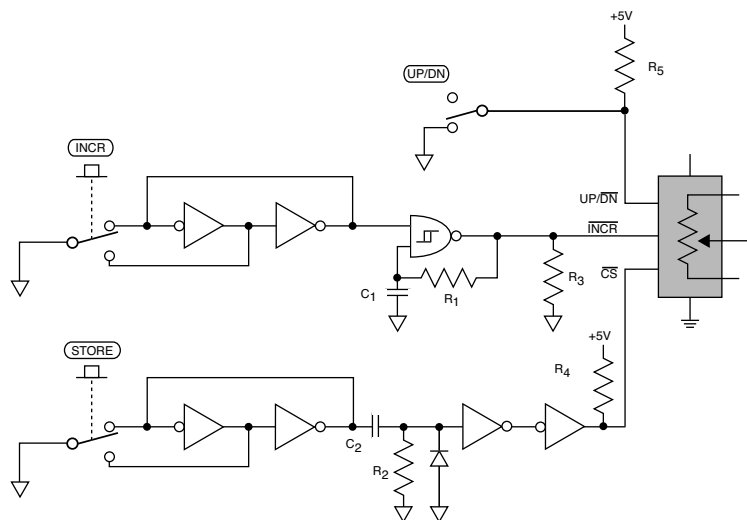

Figure 1 Push Button Controller

# **COPAL ELECTRONICS**

NIDEC COPAL ELECTRONICS CORP.  
Japan Head Office  
Nishi-Shinjuku, Kimuraya Bldg.,  
7-5-25 Nishi-Shinjuku, Shinjuku-ku, Tokyo 160-0023  
Phone: +81-3-3364-7055  
Fax: +81-3-3364-7098  
[www.copal-electronics.com](http://www.copal-electronics.com)

Publication #: 6010  
Revision: A  
Issue date: 9/14/01  
Type: Final