

# CHP

## PIANO SWITCHES (HALF PITCH)

### RoHS compliant

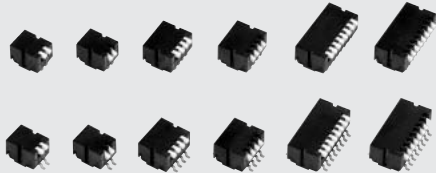

### FEATURES

- RoHS compliant
- High-reliability

### APPLICATIONS

- Communication devices, AV • OA equipment and computer peripherals

### INTERNAL STRUCTURE

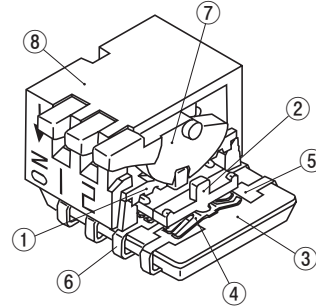

Part name	Material	Flammability
① Cover	PPS(Polyphenylenesulphide)	UL-94V-0
② Slider	PA(Polyamide)	
③ Housing	PPS(Polyphenylenesulphide)	
④ Slider contact	Copper alloy, Gold-plated	-
⑤ Fixed contact		
⑥ Terminal pin		
⑦ Piano lever	PA(Polyamide)	UL-94V-0
⑧ Piano cover	PPS(Polyphenylenesulphide)	

### PART NUMBER DESIGNATION

C H P - 0 4 0 T B

Series name

No. of bits

02 : 2 bits  
04 : 4 bits  
08 : 8 bits

ON direction

0 : Upper  
1 : Lower

Shape of terminal

A : J-hook  
B : Gull wing

Form of packaging

T : Taping (Reel)  
Blank : Bulk in plastic bag

※Please refer to the LIST OF PART NUMBERS when placing orders.

## CHP PIANO SWITCHES (HALF PITCH)

### LIST OF PART NUMBERS

No. of bits	ON direction	Form of packaging	Shape of terminals		Pieces in package
			A (J-hook)	B (Gull wing)	
2	Upper	Taping	CHP-020TA	CHP-020TB	500 pcs./reel
		Plastic bag	CHP-020A	CHP-020B	50 pcs./pack
	Lower	Taping	CHP-021TA	CHP-021TB	500 pcs./reel
		Plastic bag	CHP-021A	CHP-021B	50 pcs./pack
4	Upper	Taping	CHP-040TA	CHP-040TB	500 pcs./reel
		Plastic bag	CHP-040A	CHP-040B	50 pcs./pack
	Lower	Taping	CHP-041TA	CHP-041TB	500 pcs./reel
		Plastic bag	CHP-041A	CHP-041B	50 pcs./pack
8	Upper	Taping	CHP-080TA	CHP-080TB	500 pcs./reel
		Plastic bag	CHP-080A	CHP-080B	50 pcs./pack
	Lower	Taping	CHP-081TA	CHP-081TB	500 pcs./reel
		Plastic bag	CHP-081A	CHP-081B	50 pcs./pack

※ Verify the above part numbers when placing orders.  
Taping version can be supplied only in reel units.

### STANDARD SPECIFICATIONS

Operating temp. range	- 40 ~ 85 °C
Storage temp. range	
Sealing	Non-washable
Net weight	Approx. 0.16 g (CHP-02), Approx. 0.25 g (CHP-04), Approx. 0.43 g (CHP-08)

### ELECTRICAL CHARACTERISTICS

Contact rating Non-switching Switching Minimum	DC50 V, 100 mA DC6 V, 100 mA DC24 V, 25 mA DC20 mV 1 μA
Contact resistance	50 mΩ maximum
Insulation resistance	1000 MΩ (DC100 V) minimum
Dielectric strength	AC500 V, 60 s

### MECHANICAL CHARACTERISTICS

Operation angle	22 °
Operation force	5 N (0.51 kgf) maximum
Stop strength	10 N (1.02 kgf) 60 s
Solderability	245 ± 3 °C, 2 ~ 3 s
Soldering heat	Reflow : 255 °C (Peak temperature) Please refer to the profile below)
	Manual soldering : 350 ± 10 °C, 3 ~ 4 s
Shear (Adhesion)	5 N (0.51 kgf) 10 s
Substrate bending	Width 90 mm, bend 3 mm, 5 s, 1 time
Pull-off strength	5 N (0.51 kgf) 10 s

{ } : Reference only

### ENVIRONMENTAL CHARACTERISTICS

Vibration	Amplitude 1.5 mm or Acceleration 98 m/s <sup>2</sup> , 10-500 Hz, 3 directions for 10 cycles each
Shock	490 m/s <sup>2</sup> , 11 ms 6 directions for 3 times each
Load life	Continuous load 1000 cycles, DC6 ± 0.5 V, 100 ± 10 mA
Humidity	-10 ~ 65 °C, Relative humidity 0 ~ 96 %, 24 h for 10 cycles
High temp. exposure	85 °C, 96 h
Low temp. exposure	-40 °C, 96 h
Thermal shock	-40 (0.5 h) ~ 85 °C (0.5 h), 5 cycles

## CHP PIANO SWITCHES (HALF PITCH)

### <Reflow profile for soldering heat evaluation>

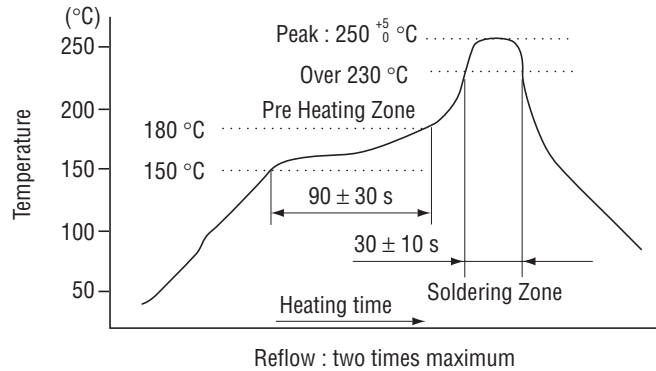

### OUTLINE DIMENSIONS

Unless otherwise specified, tolerance :  $\pm 0.3$  (Unit : mm)

#### ● CHP-020A

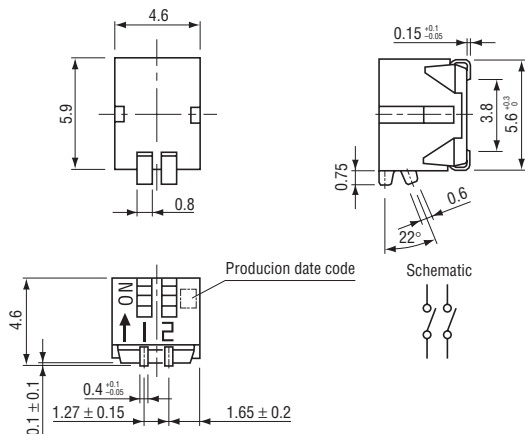

#### ● CHP-021A

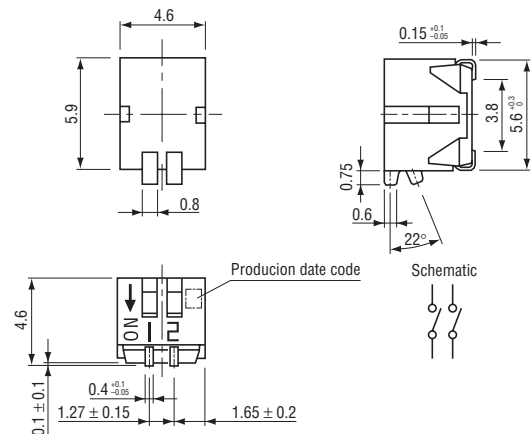

#### ● CHP-020B

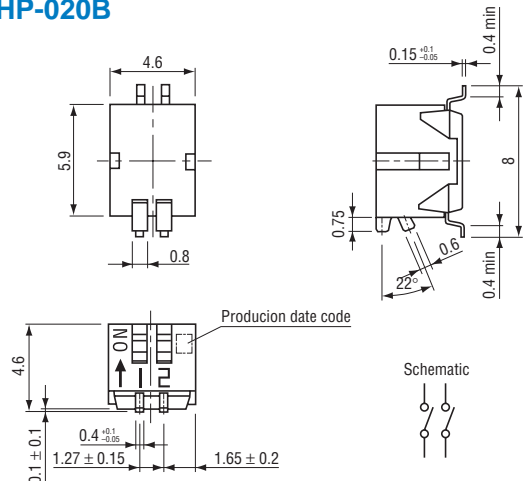

#### ● CHP-021B

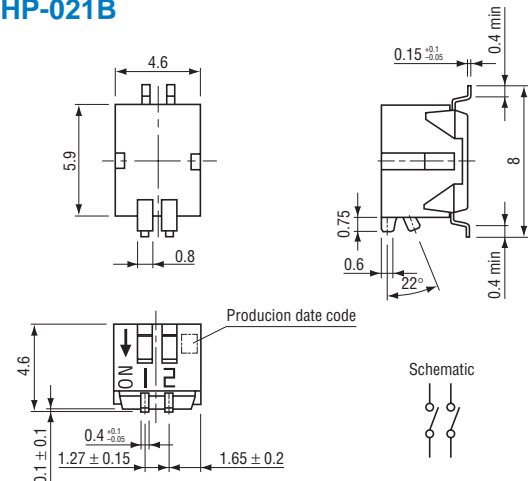

## CHP PIANO SWITCHES (HALF PITCH)

### OUTLINE DIMENSIONS

Unless otherwise specified, tolerance :  $\pm 0.3$  (Unit : mm)

#### ● CHP-040A

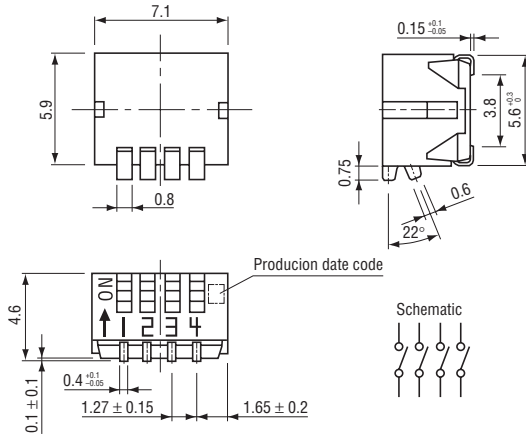

#### ● CHP-041A

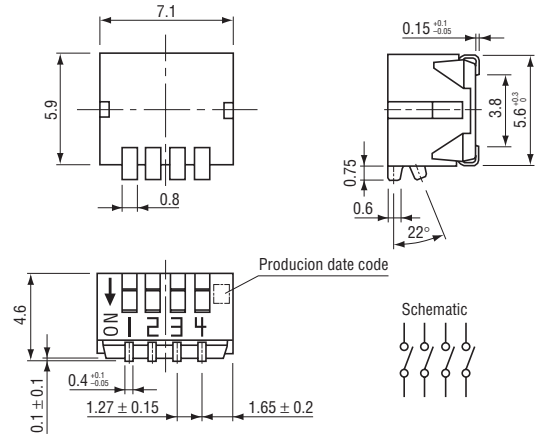

#### ● CHP-040B

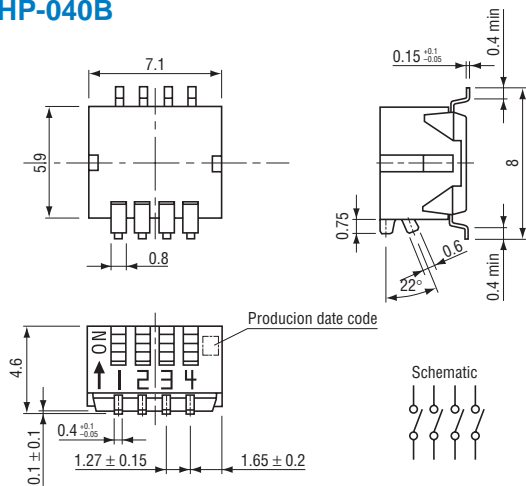

#### ● CHP-041B

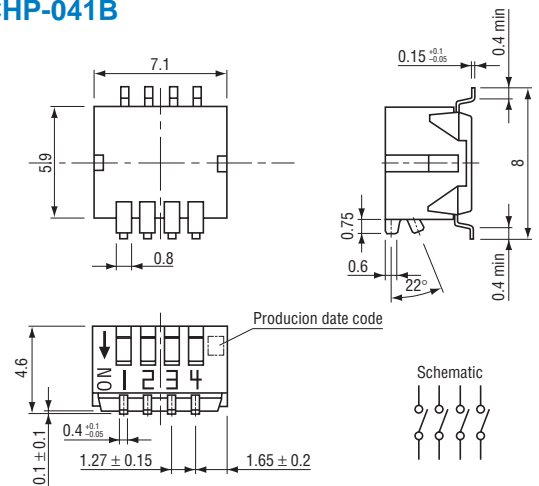

#### ● CHP-080A

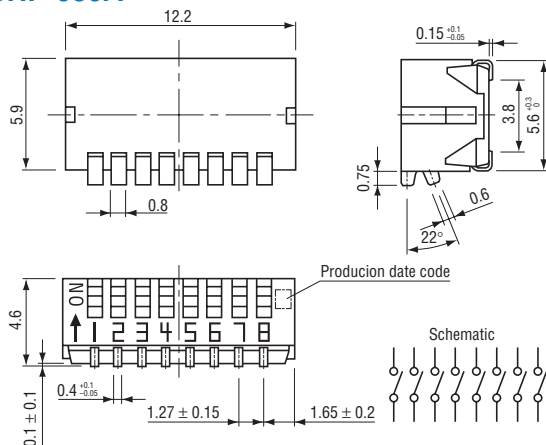

#### ● CHP-081A

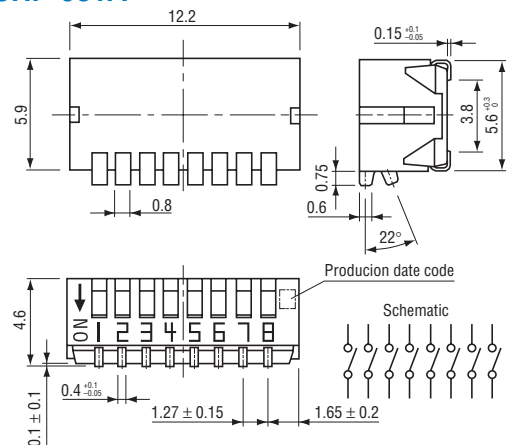

# CHP PIANO SWITCHES (HALF PITCH)

## OUTLINE DIMENSIONS

Unless otherwise specified, tolerance :  $\pm 0.3$  (Unit : mm)

### ● CHP-080B

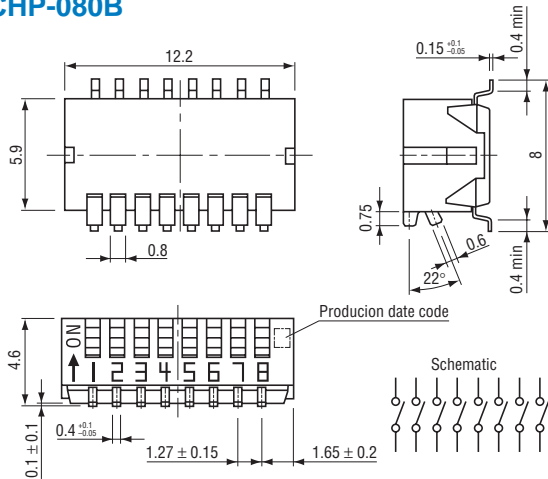

### ● CHP-081B

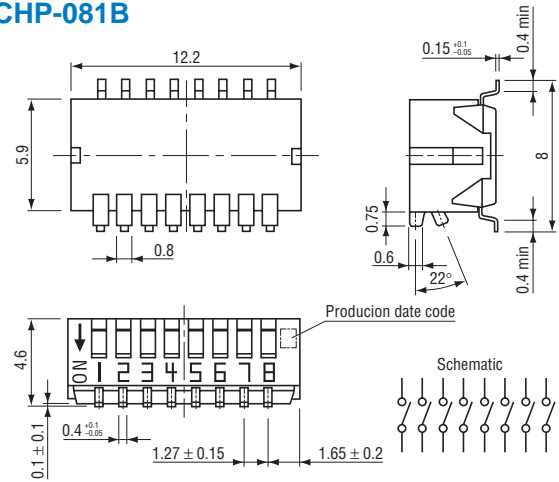

## RECOMMENDED P.C.B. PAD DIMENSIONS

### ● 2 bits A type

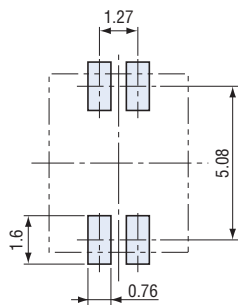

### B type

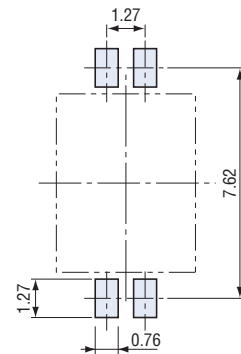

### ● 4 bits A type

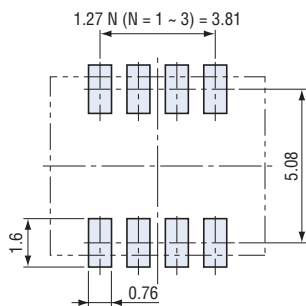

### B type

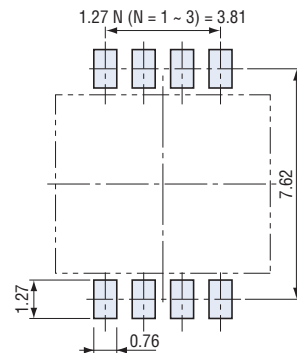

### ● 8 bits A type

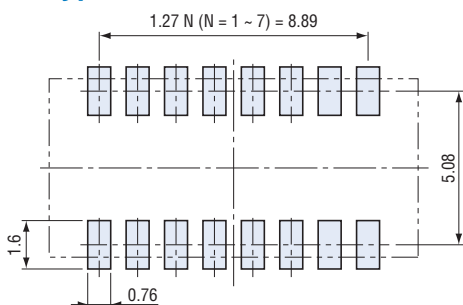

### B type

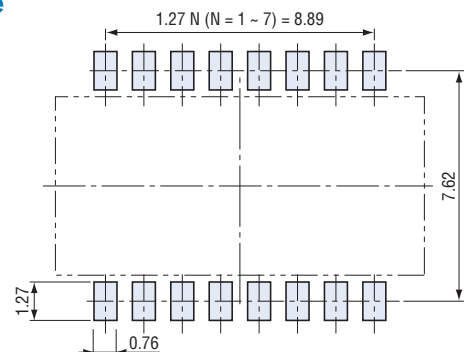

**CHP**  
**PIANO SWITCHES (HALF PITCH)**

**PACKAGING SPECIFICATIONS**

**<Taping packaging specifications>**

- Taping version is packaged in 500 pcs. per reel. Orders will be accepted for units of 500 pcs., i.e., 500, 1000, 1500 pcs., etc.
- Taping version is boxed with two reels.

Maximum number of consecutive missing pieces=2  
Leader length and reel dimension are shown in the diagrams below:

**● Embossed tape dimensions**

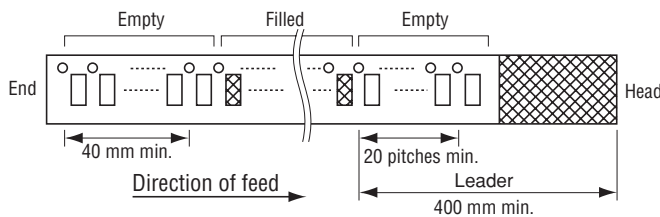

**● Reel dimensions**

(Unit: mm)  
**(Conforms to JIS C 0806-3)**  
**(In accordance with EIAJ ET-7200A)**

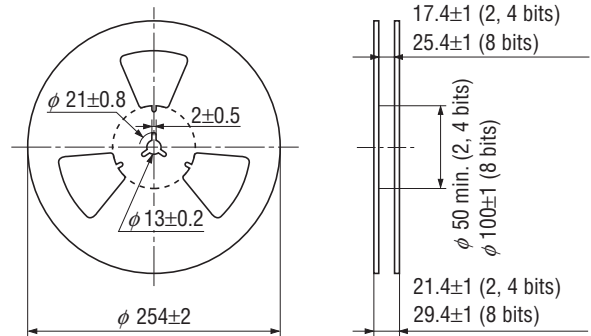

**● 2 bits**

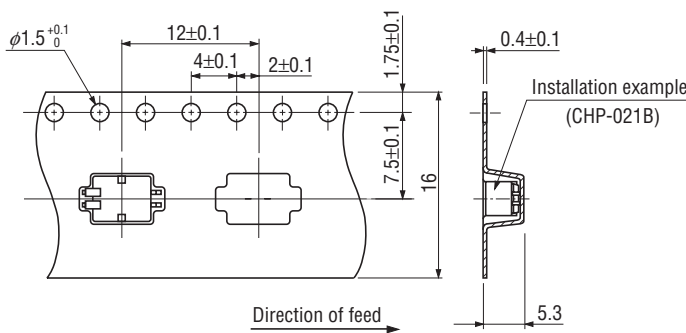

**● 4 bits**

(Unit: mm)

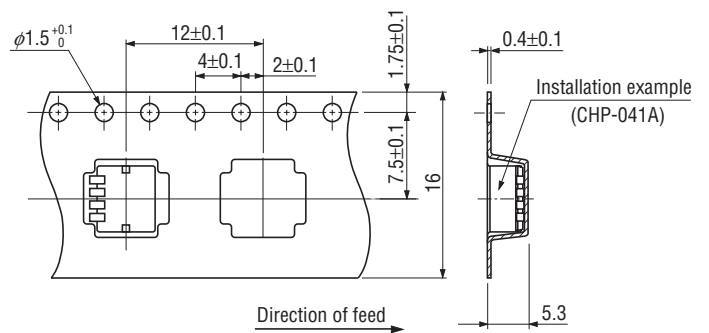

**● 8 bits**

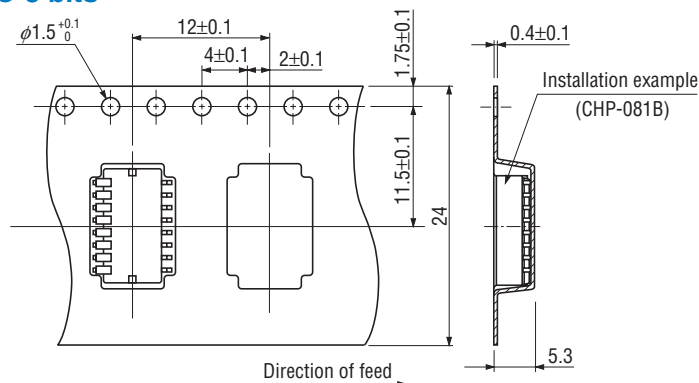

**<Bulk pack specifications>**

- The smallest unit of bulk pack in a plastic bag is 10 pcs. per pack. Orders will be accepted for unit of minimum 10 pcs., i.e., 10, 20, 30 pcs., etc.
- Boxing of bulk in a plastic bag is performed with 50 pcs. (Standard 100 pcs.) per box.