

### W-52EVAL1 EVALUATION BOARD FOR W-52 WHITE LED DRIVER

Denisa Stefan, Applications Engineer

#### 1. INTRODUCTION

This document describes the W-52EVAL1 Evaluation Board for the COPAL ELECTRONICS W-52 white LED driver. The functionality and major parameters of the W-52 can be evaluated with the W-52EVAL1.

The W-52 is a CMOS constant-current DC/DC converter that has been designed to drive with high efficiency white or other high brightness LEDs. A single external resistor sets the LED current between 5mA and 40 mA. LED current can be adjusted using either a pulse width modulated (PWM) signal or a DC voltage. Detailed descriptions and electrical characteristics are in the W-52 data sheet.

#### 2. W-52EVAL1 BOARD HARDWARE

The evaluation board contains a W-52 DC-DC boost converter and an array of white LEDs. As configured, the circuit is set to drive up to 2 banks of 4 series LED arrays. However, the user can chose a wide variety of other LED configurations using different jumper options. The board schematic is shown in Figure 1.

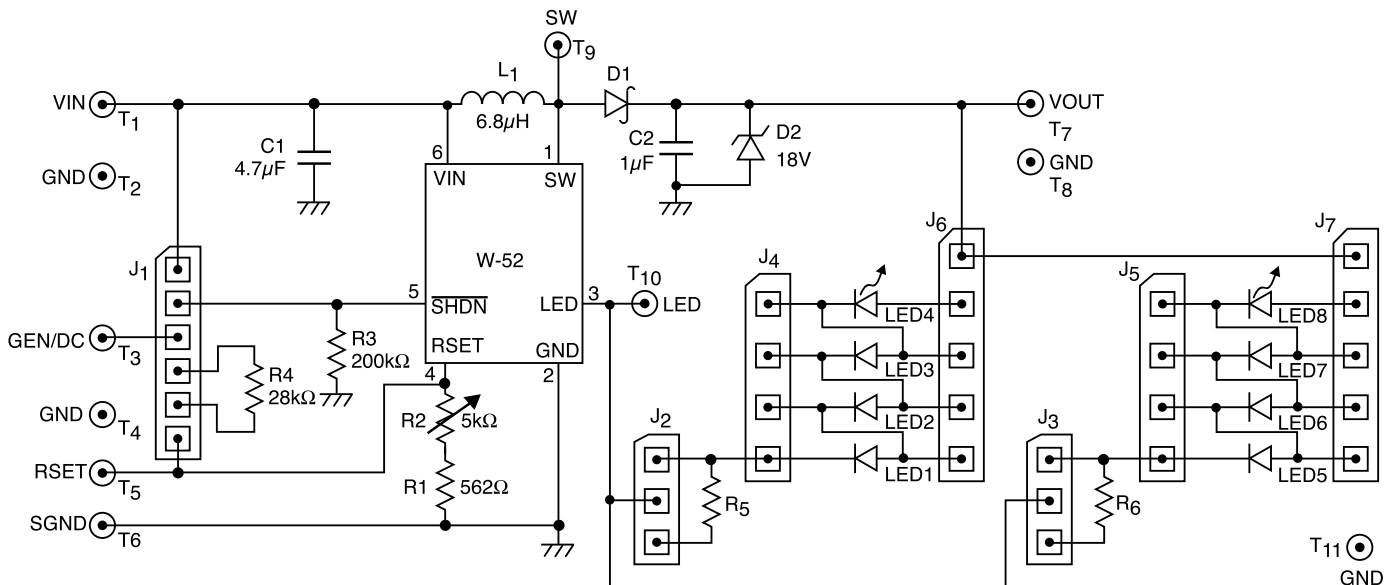

Figure 1. W-52EVAL1 Evaluation Board Schematic

## AN14

---

The board is powered from an external voltage applied to the VIN (T1) pad. The circuit is delivered without the LEDs connected to the W-52 output. To connect the LEDs to the W-52 output, connect the VOUT and LED pins to the LED strings. These connections can be made using the jumper shunts in the appropriate positions at the J6 (J7) and J2 (J3) header-pin connectors. The Zener diode, D2, clamps the output voltage VOUT at +18V for the output-open circuit configuration. The zener provides added protection when the LEDs are not connected to the W-52 output.

The designer can choose to connect the W-52 output to the white LEDs available on the board or to the LEDs in an application. The W-52EVAL1 board is available in different options:

- 2 strings of 4 LEDs, LED1 to LED8 (Nichia NSCW100) on board (W-52EVAL1-1)
- 1 string of 4 LEDs, LED1 to LED4 (Nichia NSCW100 or NSCW335) on board (W-52EVAL1-2)
- No LEDs on board (W-52EVAL1-3)

The LED current is set through the external resistors connected to the  $R_{SET}$  pin (R1, R2). Using the variable resistor R2, the LED current can be set from 5mA to 40mA. Most white LEDs are driven at a maximum current between 15mA and 20mA to ensure a pure “white” light. When the circuit is configured to drive two parallel strings of LEDs, the total current flowing into the LED pin should be 30mA to 40mA (two strings of 15mA to 20mA). Resistors R5 and R6 must be used to match the brightness of the two parallel connected LED strings.

The board also demonstrates the W-52 shutdown mode and LED brightness control by using an external PWM signal or DC voltage. The ON/OFF operation and dimming control can be selected using the jumper options for the J1 connector.

Test points T1 to T11 are available to apply the external voltages/signal generator or to measure the output voltages/signals provided by W-52.

Table 1. W-52EVAL1 Board List of Components

Name	Manufacturer	Description	Part Number	Units
U1	COPAL	CMOS White LED Driver, SOT23 - 6pin	W-52EKT	1
C1	Taiyo Yuden (or Panasonic)	Ceramic Capacitor 4.7 $\mu$ F, Size 0805	JMK212BJ475 (Digi-Key PCC2315CT-ND)	1
C2	Taiyo Yuden (or Kemet)	Ceramic Capacitor 1.0 $\mu$ F, low ESR, 0805	EMK212BJ105 (Digi-Key 399-1284-1-ND)	1
L1	Panasonic	Inductor 6.8 $\mu$ H, low DCR, 1210	ELJEA6R8 (Digi-Key PCD1422CT-ND)	1
D1	Zetex	Schottky Diode SOD-323	ZHCS400CT-ND	1
D2	Diodes	Zener Diode, 18V, 1W, SMT (SMA package)	SMAZ18DICT-ND	1
R1	Yageo	SMT Resistor 1/16W, 562 ohm, 0603	Digi-Key 311-562HCT-ND	1
R2	COPAL	Trimmer Pot, 5.0 kohm	RJ-6S 502 (or equiv)	1
R3	Yageo	SMT Resistor 1/16W, 200 kohm, 0603	Digi-Key 311-200KHCT-ND	1
R4	Yageo	Metal Film Resistor 1/16W, 28 kohm	Digi-Key 28.0KXBK-ND	1
R5, R6	Yageo	Metal Film Resistor 1/16W, 100 ohm (Not Soldered)	Digi-Key 49.9XBK-ND	
L1 to L8	Nichia	White LED, SMT (Not soldered on all boards)	NSCW100 (or NSCW335)	8
J1		6-pin Header Connector, 0.1", Single Strip	Digi_Key S1012-06-ND	1
J2, J3		3-pin Header Connector, 0.1", Single Strip	Digi_Key S1012-03-ND	2
J4, J5		4-pin Header Connector, 0.1", Single Strip	Digi_Key S1012-04-ND	2
J6, J7		5-pin Header Connector, 0.1", Single Strip	Digi_Key S1012-05-ND	2
T1 to T11	Mil-Max	Pin Receptacle (Test Points)	#0149-0-15-01-30-14-04-0	11

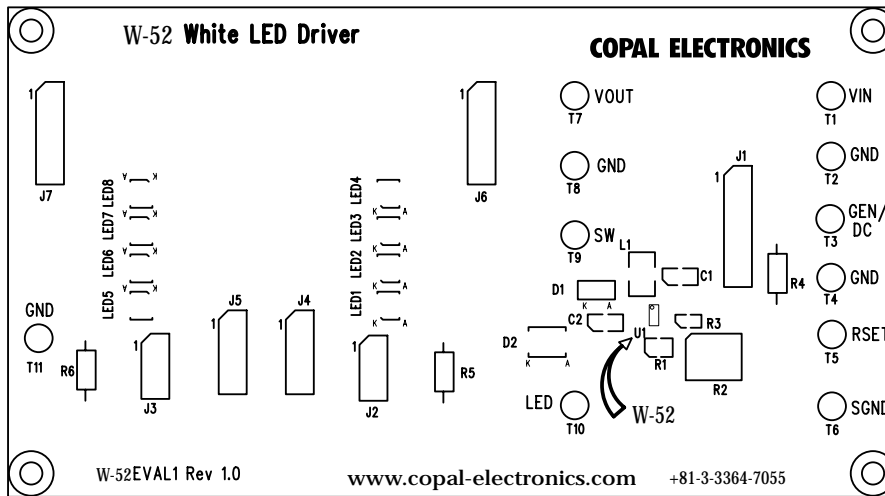

Figure 2. W-52EVAL1 Board Component Placement

### 3. W-52 EVALUATION

The W-52EVAL1 gives the user a way to evaluate the W-52 in a typical application of driving multiple LEDs. The board offers to the user the possibility to connect a different number of LEDs to the W-52 output, using the jumper options for J4, J6 or J5, J7 header-pin connectors.

This document describes the evaluation of the W-52 only in some of these configurations. The following steps are an example of how the user can evaluate the W-52 white LED driver:

#### 1) Driving 4 LEDs in Series

- a) Connect the LEDs to the W-52 output.
  - Connect VOUT to the LED string (anode terminal) using a jumper shunt between Pin #1 and Pin #2 of J6 header-pin connector.
  - Connect LED output to the LED string (cathode terminal) using a jumper shunt between Pin #1 and Pin #2 of J2 header-pin connector.
- b) Set the R2 potentiometer to the middle position.
- c) Apply the external voltage supply,  $V_{ext}$  ( $2.5V < V_{IN} < 7V$ ) between VIN (T1) and GND (T2).
- d) The W-52 is in the Shutdown Mode ( $\overline{SHDN}$  pin is connected to GND) if the J1 connector is not jumpered.
  - Connect a current meter between  $V_{ext}$  and VIN pad to measure the shutdown current:  $I_{QSHDN} < 1\mu A$
  - In this mode of operation the LEDs are disconnected from the output: LEDs are OFF
- e) Connect the W-52  $\overline{SHDN}$  pin to VIN using a jumper shunt between Pin #1 and Pin #2 of the J1 connector
  - Observe that the LEDs are ON.

#### 2) LED Current Evaluation

- a) Programming LED current

LED current is programmed using the external resistor connected to the RSET pin. The voltage at the RESET pin is internally regulated to 100mV.

The current into the LED pin can be set according to the following equation:

$$I_{LED} \text{ (mA)} = 225 \times (0.1\text{V} / R_{SET}(\text{k}\Omega)) ; R_{SET} = R1 + R2.$$

- Set VIN = 3V.
- Disconnect the jumper between Pin #1 and Pin #2 of the J6 connector and insert a current meter between these pins to monitor the LED current, ILED.
- Rotate the potentiometer R2 and observe the ILED value on the current meter. The current can be adjusted between 5mA and 40mA.
- Monitor the voltage on RSET (T5), VOUT (T7), and VLED (T10).
- Verify the internal switch functionality ( $f_{sw} = 1.2\text{MHz}$  – typically) using a scope probe connected on SW (T9) test point (GND = T8).

Figure 3 presents the internal switch output, VSW (DC coupled, 5V/div) and VOUT (AC coupled at 50mV/div) for VIN = 3V, ILED = 15mA, 4 LEDs in series connected to the W-52 output.

Figure 4 shows the ILED current measured through the voltage across a 10Ω series resistor, R5, connected between the LEDs and the LED pin.

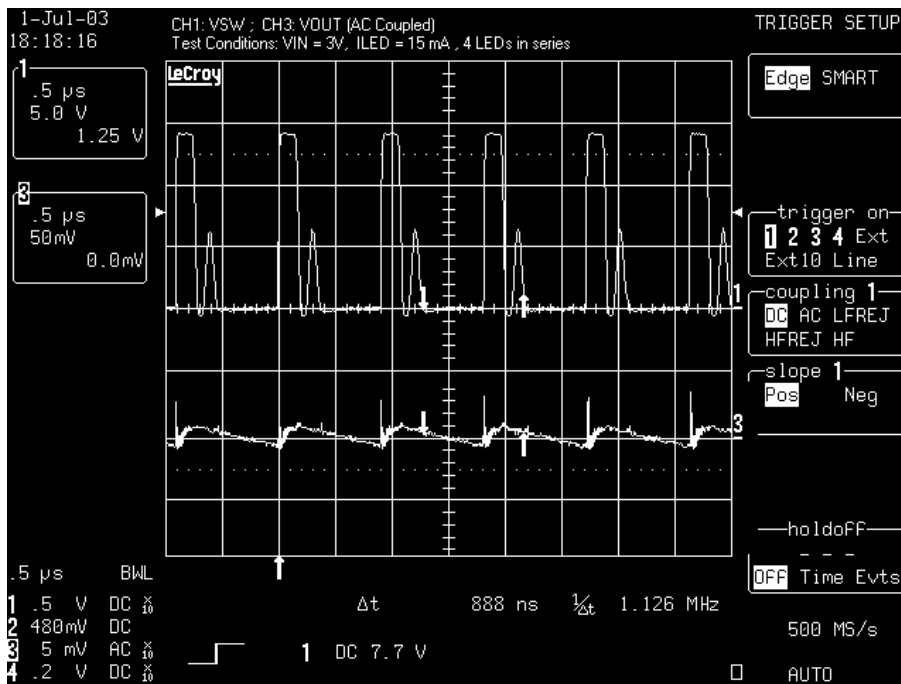

Figure 3. Internal Switch and Output Voltage Waveforms.

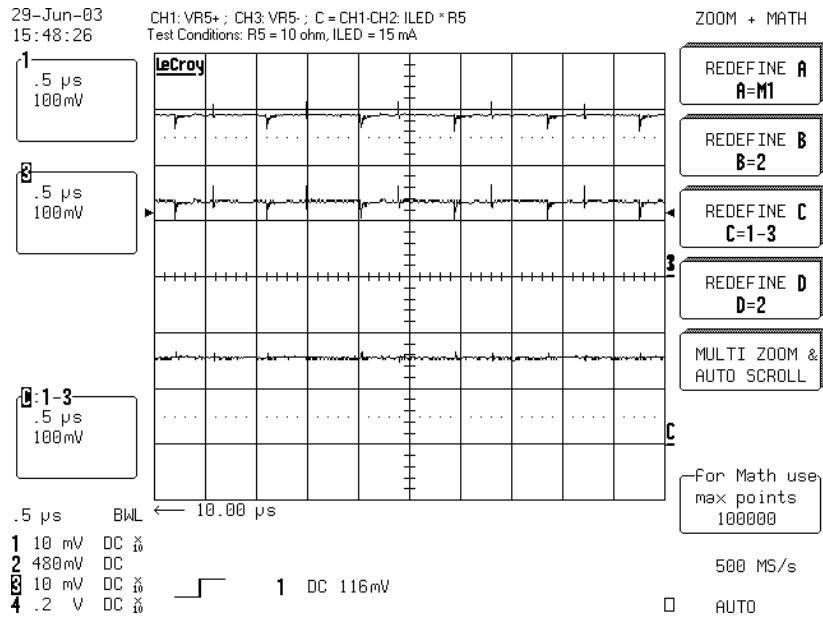

Figure 4. LED Current Waveform (ILED = 15mA)

b) Evaluating LED current regulation versus the input voltage, VIN.

- Set the ILED to a programmed value using the R2 potentiometer (i.e. 5mA, 15mA, 30mA)
- For any ILED value vary the VIN voltage between 2V and 7V
- Observe the value of ILED measured by the current meter. Figure 5 presents the ILED current versus VIN.

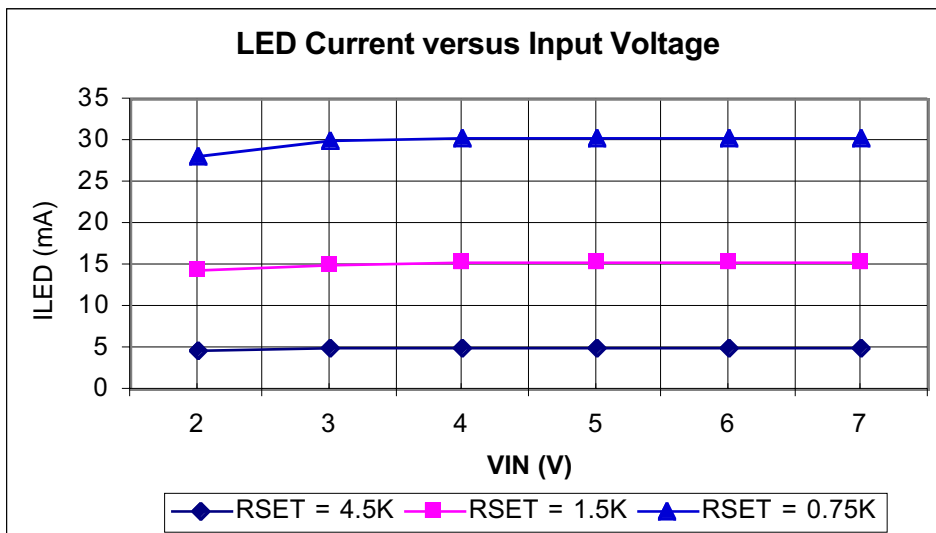

Figure 5. LED current Line Regulation

### 3) Efficiency Evaluation

The efficiency is evaluated according to the following equation:

$$\text{Efficiency \%} = (\text{ILED} \times \text{VOUT}) / (\text{IIN} \times \text{VIN}) \times 100$$

- Insert a current meter, CM1, between input supply voltage, Vext, and VIN pad to monitor the input current, IIN.
- Set the input voltage for VIN = 3V
- Adjust the R2 potentiometer for the ILED = 5mA. Observe the ILED current on the meter, CM2, inserted between VOUT and Pin #2 of J6 connector.
- Measure the IIN current on CM1
- Monitor the output voltage on VOUT (T7) and VIN voltage on VIN (T1) test points.
- Repeat steps c to e for ILED = 10mA, 15mA, and 20mA.

Figure 6 presents the efficiency measured for 2 values of input voltage, VIN = 3V and VIN = 5V, with 4 LEDs in series connected to the W-52 output. The efficiency is over 80% for the recommended LED current levels of 15mA to 20mA that ensure a pure “white” light.

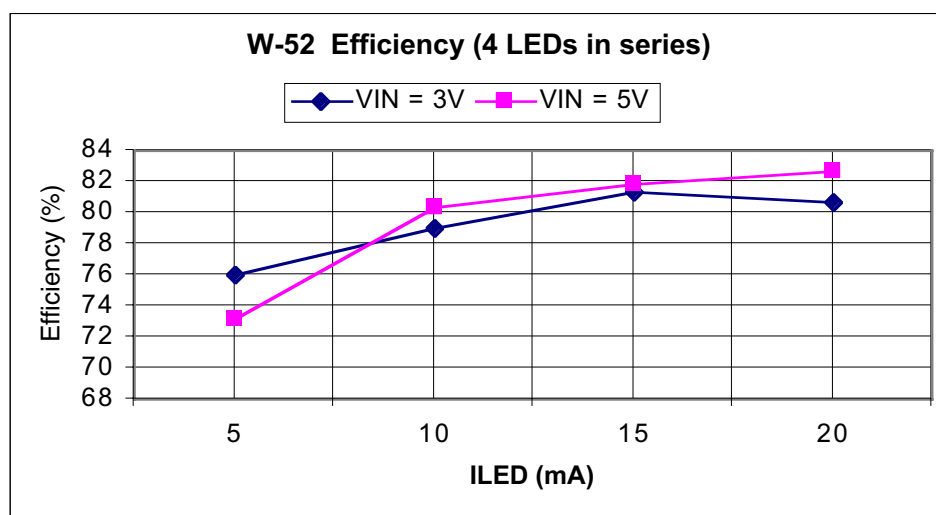

Figure 6. W-52 Efficiency driving 4 LEDs in series.

### 4) Dimming Control

The LED brightness control can be accomplished by using a PWM signal applied to the  $\overline{\text{SHDN}}$  pin or to the RSET pin. The other method is to use a variable DC voltage applied through a resistor to RSET pin.

- Dimming using a PWM signal on the  $\overline{\text{SHDN}}$  pin.

The LEDs are turned off and on at the PWM frequency. The average current changes with the duty cycle. Increasing the duty cycle will increase the LED brightness. The peak current value sets the light spectrum.

- Connect the jumper shunt between Pin #2 and Pin #3 of the J1 connector.
- Apply a pulse signal generator to the GEN/DC (T3) pad; Frequency = 5kHz to 40kHz; Amplitude 0V to 3V for VIN = 3V.
- Modify the duty cycle between 0% and 100%.
- Observe the average current through LEDs. For 0% duty cycle, the ILED will be off (ILED = 0mA); at the maximum duty cycle, the LED will be driven at the maximum current set by the R2 potentiometer.

Figure 7 shows the ILED current using a PWM signal applied to the  $\overline{\text{SHDN}}$  pin.

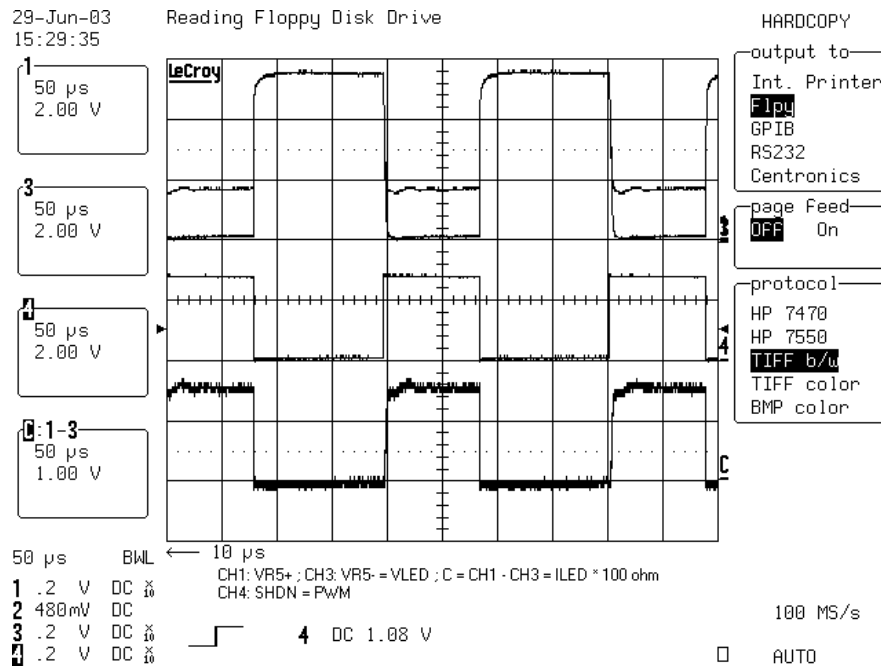

Figure 7. LED Current Waveform with PWM

b) Dimming using a PWM signal at the RSET pin.

When the RSET pin is used for dimming, increasing the PWM duty cycle will decrease the LED current. The PWM signal is applied to the RSET pin through a series resistor,  $R_{\text{PWM}} = R4$ . The value of series resistor  $R4$  can be calculated according to:

$$R_{\text{PWM}} = \text{RSET} \times (V_{\text{MAX}} / 0.15 - 1) ; \text{ where } V_{\text{MAX}} = \text{VIH of the PWM signal.}$$

- Connect the  $\overline{\text{SHDN}}$  pin to VIN: jumper shunt between Pin #1 and Pin #2 of the J1 connector.
- Connect the GEN/DC to RSET through resistor  $R4$  using one jumper between Pin #3 and Pin #4 and another jumper shunt between Pin #5 and Pin #6 of the J1 connector.
- Apply the pulse signal generator between GEN/DC (T3) and GND (T4).
- Modify the duty cycle and observe the average ILED current.

c) Dimming using a DC voltage

A variable DC voltage is applied to the  $R_{\text{SET}}$  pin through a series resistor,  $R_{\text{ADJ}} = R4$ . As the DC voltage is increased, the current flowing out of the  $R_{\text{SET}}$  pin is reduced, thus the LED current decreases. For a LED current change between  $I_{\text{LED}_{\text{MAX}}}$  and  $I_{\text{LED}_{\text{MIN}}}$ , the series resistor is determined by the following formula:

$$R_{\text{ADJ}} = 225 \times (V_{\text{MAX}} - 0.1) / (I_{\text{LED}_{\text{MAX}}} - I_{\text{LED}_{\text{MIN}}}) ; \text{ where } V_{\text{MAX}} \text{ is the maximum applied DC voltage.}$$

- Connect the  $\overline{\text{SHDN}}$  pin to VIN: jumper shunt between Pin #1 and Pin #2 of J1 connector.
- Connect the GEN/DC to RSET through  $R4$  resistor using one jumper between Pin #3 and Pin #4 and another jumper shunt between Pin #5 and Pin #6 of J1 connector.
- Apply the variable DC voltage between GEN/DC (T3) and GND (T4).
- Increase the DC voltage value from 0V to  $V_{\text{MAX}}$ .

- Observe that the ILED current decreases from the  $I_{LED\_MAX}$  (15mA – previous set) to  $I_{LED\_MIN}$  (0mA for  $V_{MAX}$ ).

### 5) Driving 8 LEDs (2 parallel strings of 4 LEDs)

The W-52EVAL1 board offers the possibility to connect 8 LEDs to the W-52 output: 2 parallel strings of 4 LEDs in series. In order to match the brightness of the two LEDs strings, the user should mount the series resistors R5 and R6. The recommended value for these resistors is 75 to 100 ohms.

#### a) Connect the LEDs and verify functionality

- Connect VOUT to the LED strings using the jumper shunts between Pin #1 and Pin #2 of the J6 connector and Pin #1 and Pin #2 of the J7 connector.
- Connect the LED pin through resistors R5 and R6 to the other end of LED strings; connect the jumper shunts between Pin #2 and Pin #3 of the J2 connector and Pin #2 and Pin #3 of the J3 connector.
- Set the R2 potentiometer for  $R_{SET} = 1.5 \text{ kohm}$ .
- Verify the SHDN pin is connected to VIN: jumper a shunt across Pin #1 and Pin #2 of the J1 connector.
- Apply  $VIN = 3V$
- Observe that the two LED strings are ON: LED current is about 7.5mA so the LEDs are moderately bright

#### b) Efficiency Evaluation

The efficiency is determined as described above at point #3). This time, the total LED current should be considered as the output current.

$$\text{Efficiency \%} = (I_{LED\_Total} \times V_{OUT}) / (I_{IN} \times V_{IN}) \times 100$$

- Connect the current meter in series with every LED string to measure ILED1 and ILED2, where  $I_{LED1} + I_{LED2} = I_{LED\_Total}$
- Apply the  $VIN$  voltage (i.e.  $VIN = 3V$ ).
- Set the R2 potentiometer for  $I_{LED\_Total} = 10\text{mA}$  (5mA through every string)
- Measure the  $I_{IN}$ , using the current meter inserted between Vext and VIN pin.
- Monitor VOUT and VIN voltages.
- Repeat for other values of  $I_{LED\_Total}$ : 15mA, 20mA, 25mA, and 30mA.

Figure 8 presents the efficiency for W-52 driving 8 LEDs for  $VIN = 3V$  and  $VIN = 5V$ .

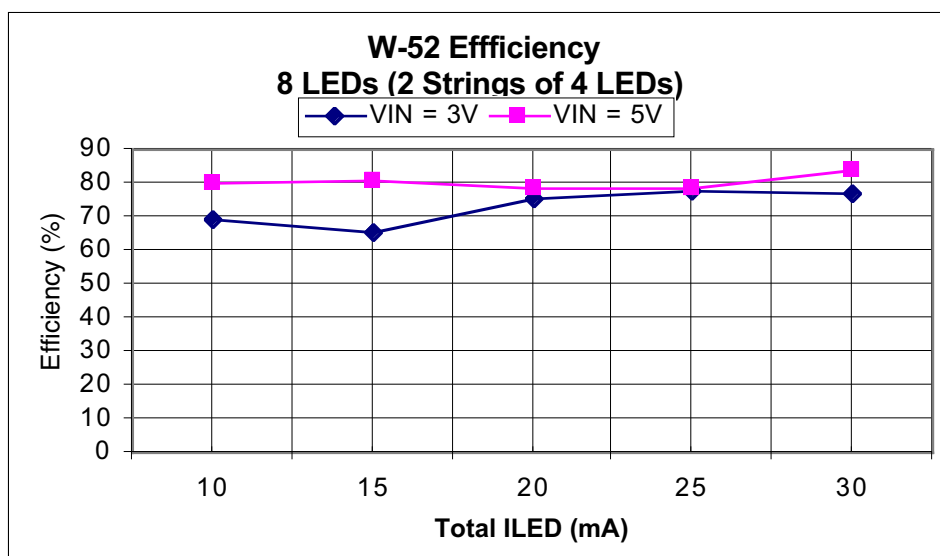

Figure 8. W-52 Efficiency Driving 2 Parallel Strings of 4 LEDs in Series

# **COPAL ELECTRONICS**

NIDEC COPAL ELECTRONICS CORP.  
Japan Head Office  
Nishi-Shinjuku, Kimuraya Bldg.,  
7-5-25 Nishi-Shinjuku, Shinjuku-ku, Tokyo 160-0023  
Phone: +81-3-3364-7055  
Fax: +81-3-3364-7098  
[www.copal-electronics.com](http://www.copal-electronics.com)

Publication #: 6028  
Revision: C  
Issue date: 7/29/03  
Type: Final