

W-5604EVAL1 EVALUATION BOARD FOR W-5604 WHITE LED DRIVER

Denisa Stefan, Applications Engineer

INTRODUCTION

This document describes the W-5604EVAL1 Evaluation Board for the COPAL ELECTRONICS W-5604 white LED driver. The functionality and major parameters of the W-5604 can be evaluated with the W-5604EVAL1 board.

The W-5604 is a 4-channel charge pump that has been designed to drive up to 4 LEDs connected in parallel. The W-5604 is operating in either 1x (LDO) mode, or 1.5x mode and provides tightly matched regulated current through the four LED outputs. A single external resistor sets the LED current between 2mA and 30 mA. LED current can be adjusted using either a pulse width modulated (PWM) signal or a DC voltage. Detailed descriptions and electrical characteristics are in the W-5604 data sheet.

W-5604EVAL1 BOARD HARDWARE

The evaluation board contains the W-5604 in a typical application circuit, driving up to 4 white LEDs. The user can connect, or disconnect, the W-5604 outputs to the white LEDs using the jumper options for J2, J3, J4, J5 and J6 connectors. The board schematic is shown in Figure 1.

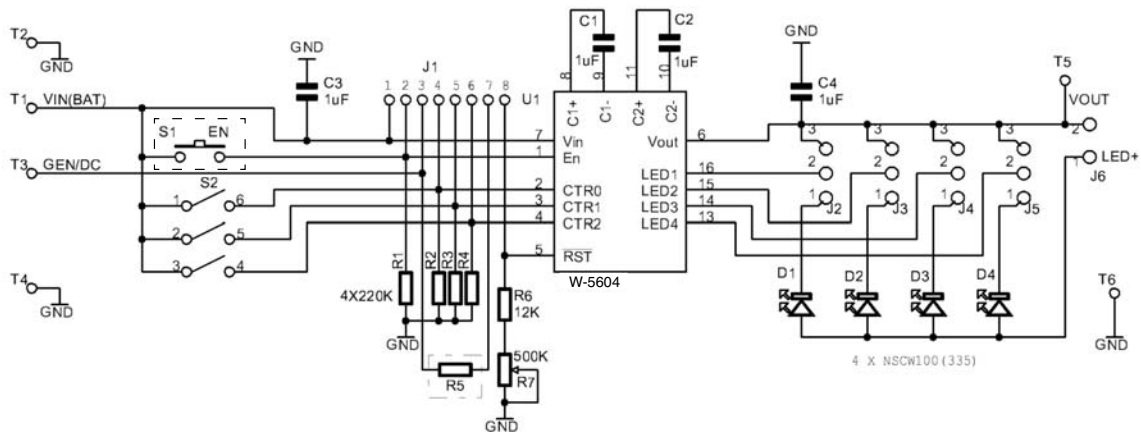

Figure 1. W-5604EVAL1 Board Schematic

The board is powered from an external voltage applied to the VIN (T1) pad. The W-5604 features three control inputs, CTR0, CTR1, CTR2, which allow turning ON / OFF each LED. The user can control the CTR0, CTR1, CTR2 inputs using the S2 DIP switch.

The LED current is set through the external resistors connected to the RSET pin (R6, R7). Using the variable resistor R7, the LED current can be set from 2mA to 30mA. Most white LEDs are driven at a maximum current between 15mA and 20mA to ensure a pure “white” light.

AN20

The board also demonstrates the W-5604 shutdown mode and LED brightness control by using an external PWM signal, or DC voltage. Resistor R5 (soldered on board by the user) is used to adjust the LED current using the dimming control with an external applied DC voltage on the RSET pin. The ON/OFF operation, using the enable (EN) input and dimming control, can be selected using the jumper options for the J1 connector.

Test points T1 to T6 are available to apply the external voltages/signal generator, or to measure the output voltages/signals provided by the W-5604. The L1 to L4 pads are also available as test points for the W-5604 LED1 to LED4 outputs.

Table 1 shows the component list for this evaluation board. The component placement and board picture are shown in Figure 2.

Table 1. W-5604EVAL1 Board List of Components

Name	Manufacturer	Description	Part Number	Units
U1	COPAL	Charge Pump White LED Driver, QFN16	W-5604	1
C1 to C4	Murata Electronics	Ceramic Capacitor 1uF / 10V, 10%, X5R, Size 0805	GRM219R61A105KC01D (Digi-Key 490-1702-1-ND)	4
R1 to R4	Yageo	SMT Resistor 1/16W, 200 Kohm, 0603	Digi-Key 311-200KHCT-ND	4
R5	Yageo	Metal Film Resistor 1/16W (Not soldered on board)	Digi-Key 40.0KXBK-ND	
R6	Yageo	SMT Resistor 1/16W, 12 Kohm, 0603	Digi-Key 311-12KHCT-ND	1
R7	COPAL	Trimmer Pot, 1/4", 500 Kohm	RJ-6S 504 (or equiv)	1
D1 to D4	Nichia	White LED, SMT	NSCW100 (or NSCW335)	4
J1		8-pin Header Connector, 0.1", Single Strip	Digi-Key S1012-08-ND (or equiv)	1
J2 to J5		3-pin Header Connector, 0.1", Single Strip	Digi-Key S1012-03-ND (or equiv)	4
J6		2-pin Header Connector, 0.1", Single Strip	Digi-Key S1012-02-ND (or equiv)	1
S1	E-Switch	Momentary Contact Switch, SPST (on)-off, Not soldered on board	TL1100F160Q (Digi-Key EG1821-ND)	1
S2	C&K	Dip Switch, Low Profile, 3Pos, SPST	SDA03H1KD (Digi-Key CKN1277-ND)	1
T1 to T6	Mil-Max	Pin Receptacle (Test Points)	#0149-0-15-01-30-14-04-0 (or equiv)	6

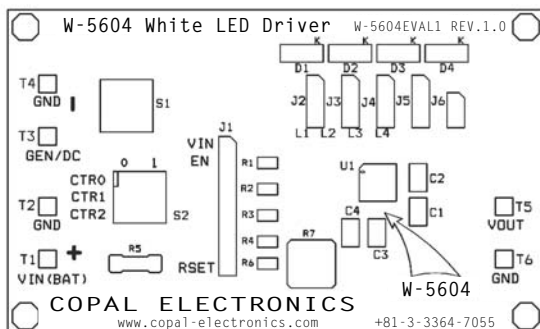

Figure 2. W-5604EVAL1 Board

W-5604 EVALUATION

The W-5604EVAL1 gives the user a way to evaluate the W-5604 in a typical application of driving multiple LEDs.

The user can connect up to 4 LEDs to the W-5604 output, using the jumper options for J2, J3, J4, J5 and J6 header-pin connectors.

The following steps are an example of how the user can evaluate the W-5604 white LED driver:

1) Driving 4 LEDs, Shutdown Mode and Open Circuit Configuration

- a) Connect the LEDs to the W-5604 output.
 - Connect VOUT to the LEDs anode terminal (LED+) using a jumper shunt between Pin #1 and Pin #2 of J6 header-pin connector.
 - Connect each LED cathode terminal to the W-5604 outputs, LED1 to LED4, using the jumper options (Pin #1 and Pin #2) for J2 to J5 header pin connectors.
- b) Set the R7 potentiometer to the middle position.
- c) Apply the external voltage supply, V_{ext} ($3.0 < V_{IN} < 5.0V$) between VIN (T1) and GND (T2).
- d) The W-5604 is in the **shutdown mode** (EN pin is connected to GND) if the J1 connector is not jumpered (Pin #1, Pin #2).
 - Connect a current meter, IM1, between V_{ext} and VIN pad to measure the shutdown current: $I_{QSHDN} < 1\mu A$
 - Using the S1 switch set the combination for the W-5604 control inputs in order to have all 4 LEDs ON: CTR0 = "0", CTR1 = CTR2 = "1".
 - The current measured by IM1 includes the currents through two pull-down resistors, R3 and R4 (each 200kohm) at CTR1 and CTR2 inputs: $I_{INmeas} = 2 \times V_{IN}/200kohm + I_{QSHDN}$. For example, with $V_{IN} = 3.3V$, the current measured is approximately 33 μA ($2 \times 3.3V/200k$). This result translates to a W-5604 shutdown current near zero ($< 1\mu A$).

For the accurate measurement of the I_{QSHDN} current, the user can temporarily remove the pull-down resistors.

AN20

e) Connect EN pin of the W-5604 to VIN using a jumper shunt between Pin #1 and Pin #2 of J1 connector

- Observe that LEDs are ON. All 4 LEDs are ON for CTR0, CTR1, CTR2 = (011)
- Change the S1 switch positions to control the CTR0, CTR1, CTR2 inputs in order to set a different combination of LEDs turned ON/OFF, according to the following table.

CTR2	CTR1	CTR0	LED1	LED2	LED3	LED4
0	0	0	-	-	-	ON
0	0	1	-	-	ON	-
0	1	0	-	ON	-	-
0	1	1	ON	-	-	-
1	0	0	-	-	ON	ON
1	0	1	-	ON	ON	ON
1	1	0	ON	ON	ON	ON
1	1	1	-	-	-	-

Note: The W-5604EVAL1 board contains the first silicon of the W-5604 (engineering samples). For this silicon, the control signals activate the LED1 to LED4 outputs in the opposite order compared with the final silicon. The data sheet reflects the final configuration that will be implemented in the next revision of silicon. For the application using 4 LEDs, this changed configuration does not matter.

f) The LED channels may be deactivated by connecting the respective LED outputs to VOUT.

- Connect the LED_i (i = 1 to 4) pin directly to VOUT using the jumper between the Pin #2 and Pin #3 of J2 to J5 connectors.
- Observe the LED sink current for the disabled channel measured by the current meter connected between the Pin #2 (LED_i) and Pin #3 (VOUT) of the corresponding header pin connector (J2 to J5): typical 20 uA - 30 uA.

g) Disconnect the LEDs from the W-5604 output: remove the jumper shunt from the J6 connector. J2 to J5 connectors have a jumper shunt between Pin #1 and Pin #2. Observe the open circuit configuration functionality for EN = "1", CTR0, CTR1, CTR2 = ("011")

- Observe the quiescent current, I_Q, measured by the current meter connected between the Vext and VIN (T1) pin: I_Q = 2.7mA – 3 mA typically.
- Observe the W-5604 output using a scope probe connected on VOUT (T5) test point (GND = T6). In this configuration with output open circuit the W-5604 operates in 1.5x mode: VOUT = 1.5 x VIN. For higher VIN than 4.2V approximately, the device switches to 1x mode operation to protect the output: VOUT max = 6V.

Figure 3 shows the output voltage, VOUT for VIN = 4.2V, open circuit configuration.

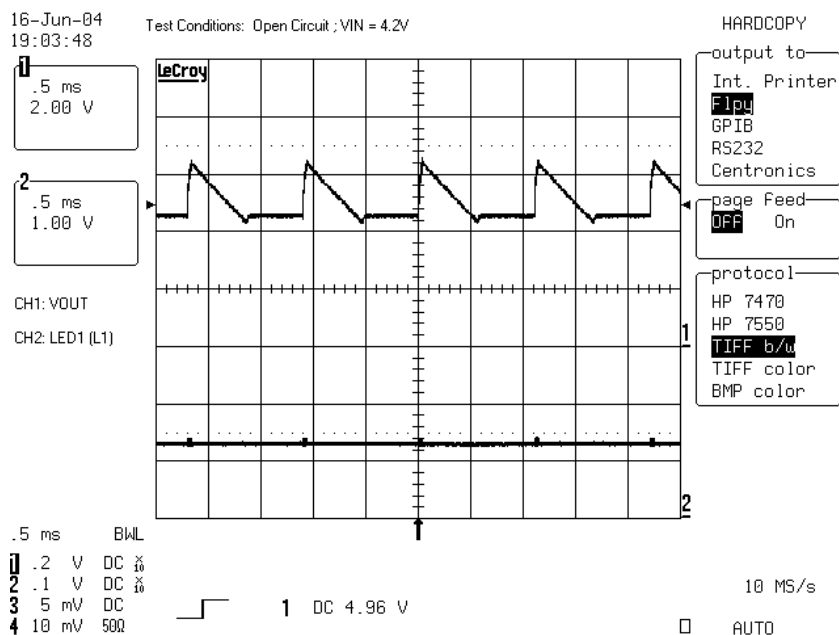

Figure 3. The Output Voltage Wavefrm for Open Circuit Configuration, VIN = 4.2V

2) LED Current Evaluation

2.1) Programming LED current

LED current is programmed using the external resistors, $R_{SET} = R_6 + R_7$, connected to the RSET pin. The voltage at the RSET pin is internally regulated to the typical value of 1.2V.

The user can set the LED current using the variable resistor, R7. The following steps are an example for the ILED programming.

- Set the input voltage: ex. $V_{IN} = 3.6V$.
- Disconnect the jumper between Pin #1 and Pin #2 of the J2 connector and insert a current meter between these pins to monitor the LED current, ILED1.
- Rotate the potentiometer R7 and observe the ILED1 value on the current meter. Various LED current values and the associated RSET value are listed below:

ILED (mA)	RSET (Kohm)
2	280
5	102
10	50
15	30
20	21
25	17.6
30	15

The W-5604EVAL1 board uses the R7 = 500 Kohm potentiometer in order to demonstrate the wide range for the ILED setting. The user can use a smaller value variable resistor for a reduced variation range and more precised setting of the LED current.

2.2) LED Current Matching

The LED current is regulated to a value programmed by the user. The four LED output currents, ILED1 to ILED4, are tightly matched to provide uniformity of LEDs brightness.

The W-5604EVAL1 board provides the user a way to evaluate the current through each LED connected to the W-5604 outputs.

The current matching between the 4 LED outputs can be calculated by the following expression:

$$\Delta I (\%) = (I_{LEDmax} - I_{LEDmin}) / (I_{LEDmax} + I_{LEDmin}) \times 100$$

where the ILEDmax and ILEDmin are the highest and respectively the lowest value of the four LED currents.

The following procedure may be used to evaluate the LED currents regulation versus input voltage and the current matching between the LEDs.

- Set the ILED to a programmed value using the R7 potentiometer (i.e. 15mA for VIN = 3.2V)
- Vary the VIN voltage between 3.2V and 5.2V
- For every VIN, observe the value of each ILED measured by the current meter inserted between the LED cathode terminal and associated W-5604 LED output (use the J2 to J5 header pin connectors).

Figure 4 shows the LED current regulation versus input voltage for all 4 LEDs and the LED to LED current matching (DI).

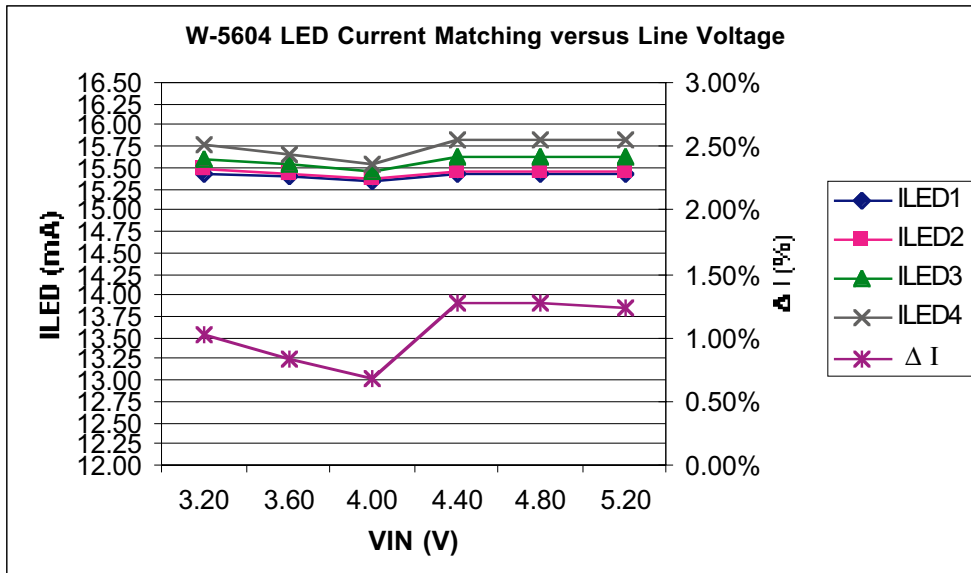

Figure 4. LED to LED Current Matching versus Line Voltage, 4 LEDs @ 15mA

3) Efficiency Evaluation

The efficiency is evaluated according to the following equation:

$$\text{Efficiency \%} = (\sum V_{Fi} \times I_{LEDi}) / (I_{IN} \times V_{IN}) \times 100$$

where $V_{Fi} = V_{OUT} - V_{LEDi}$ is the voltage dropout across the LED $_i$, I_{LEDi} is the current through one LED; $i = 1$ to 4.

3.1) Efficiency Evaluation versus Line Voltage

- Set the configuration for 4 LEDs ON at $I_{LED} = 15$ mA.
- Insert a current meter, IM1, between input supply voltage, V_{ext} , and VIN pad and monitor the input current, I_{IN} .
- Set the input voltage for the initial value $V_{IN} = 3$ V. Monitor V_{IN} at VIN (T1) test point with a voltage meter.
- Measure the output voltage on V_{OUT} (T5)
- Measure each V_{LED} output voltage on L1, L2, L3, L4 pads available on board.
- Repeat all the above measurements for V_{IN} increase between 3V and 5.0V.
- Repeat the same measurements for V_{IN} decrease from 5.0V to 3.0V.

Figure 5 and Figure 6 respectively, show the W-5604 input current (I_{IN}) and output voltage (V_{OUT}) versus line voltage using 4 LEDs driven at 15mA. The values named with + are for V_{IN} increase and the values named with – are taken for V_{IN} decrease.

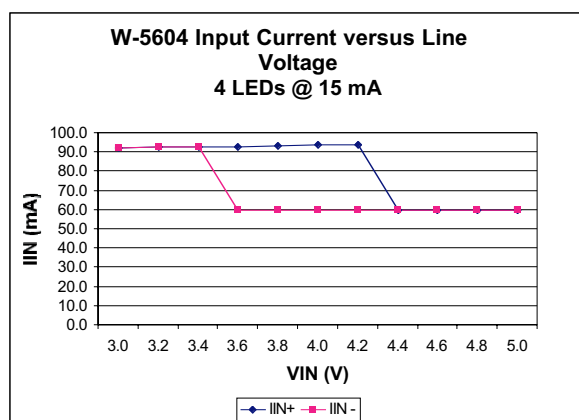

Figure 5. Input Current versus Line Voltage

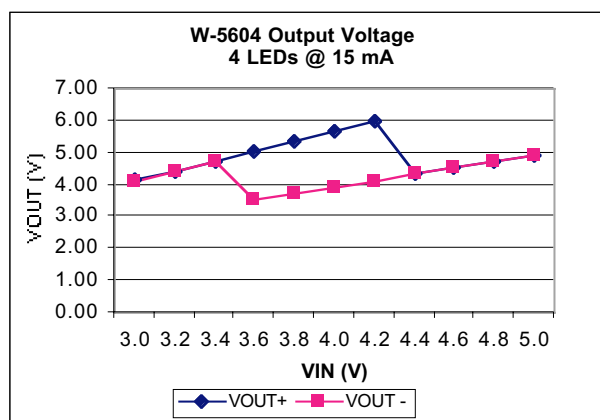

Figure 6. Output Voltage versus Line Voltage

The internal switch frequency, typical 1 MHz, is shown in the waveforms from the Figure 7; CH2: signal measured on the C2+ pad, CH1: output voltage, V_{OUT} (1.5x mode, $V_{IN} = 3.2$ V).

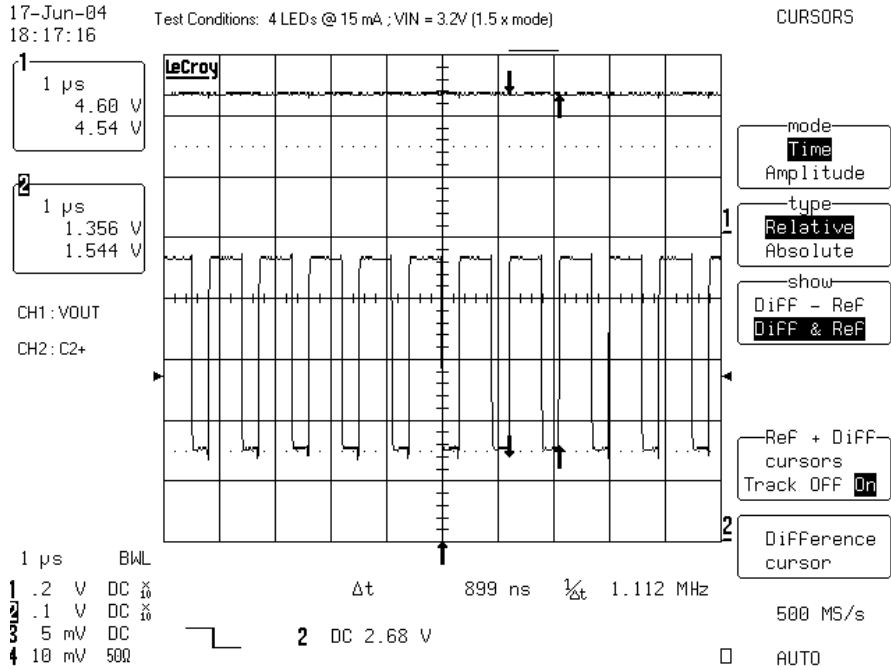

Figure 7. Output Voltage and Internal Switch (VIN = 3.2V, IOU_T = 60mA)

The W-5604 efficiency versus line voltage with 4 LEDs driven at 15 mA, is shown in Figure 8. The W-5604 efficiency is optimized for Li-Ion battery applications. At the nominal battery voltage value, the W-5604 operates in 1x mode providing a high efficiency (>80%). The 1x mode of operation is provided until VIN drops below 3.5V typically. At this point the device switches to 1.5x operation mode. In the battery powered applications, the decrease of the line voltage (battery voltage) should be taken in consideration.

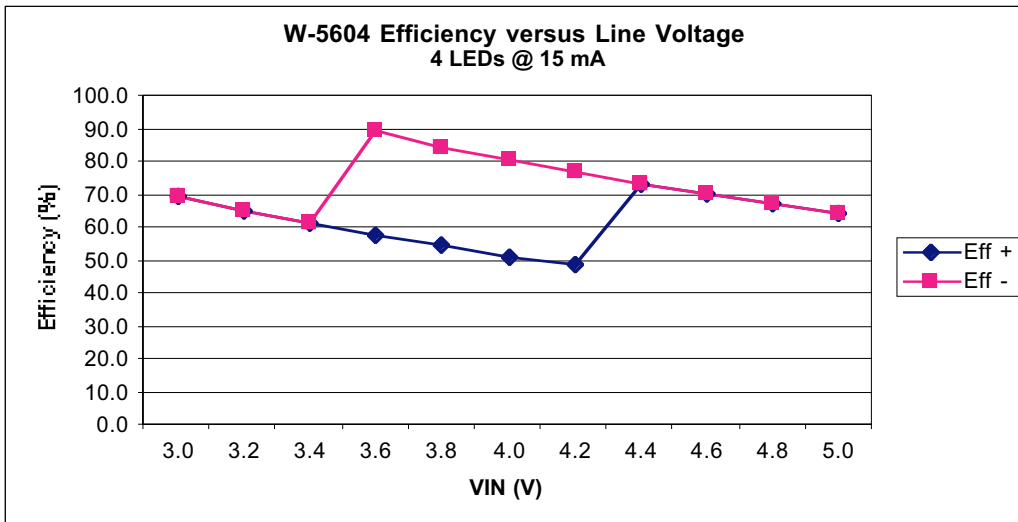

Figure 8. W-5604 Efficiency versus Line Voltage

3.2) Efficiency Evaluation versus Load

The W-5604 efficiency can also be evaluated versus the total output current driven through the LEDs. The following steps are an example of efficiency measurements for different output current values at two input voltage values.

- a) Set the configuration for 4 LEDs driven by the W-5604 device.
- b) Insert a current meter, IM1, between input supply voltage, Vext, and VIN pad and monitor the input current, IIN.
- c) Set the input voltage for VIN = 3.2V. Measure the input voltage at VIN (T1) test point with a voltage meter.
- d) Insert a current meter IM2 between the Pin #1 and Pin #2 of J6 connector to monitor the total output current, IOU_T.
- e) Adjust the R7 potentiometer for the IOU_T = 20 mA (ILED = 5 mA).
- f) Power Off the device (Vext = Off)
- g) Set EN = 0 (disconnect the jumper from J1 connector, Pin #1 and Pin #2)
- h) Disconnect the current meter, IM2 from the output and connect the jumper on J6 connector
- i) Power On the device (apply Vext with EN = "0")
- j) Set EN = 1 (insert the jumper on J1 connector)
- k) Observe the IIN current on the IM1 meter.
- l) Measure the output voltage on VO_{U_T} (T5) pin.
- m) Measure all the LED outputs voltages on L1 to L4 pads.
- n) Repeat steps d) to m) for the total output current IOU_T = 40 mA, 60 mA, 80 mA, 100 mA and 120 mA

All the above steps can also be performed for the other input voltage, i.e. VIN = 4.0V.

Note that the device must be powered in the shutdown mode in order to start the operation in 1x mode.

Figure 9 shows the W-5604 efficiency versus the total output current driven through the LEDs for VIN = 3.2V and VIN = 4.0V.

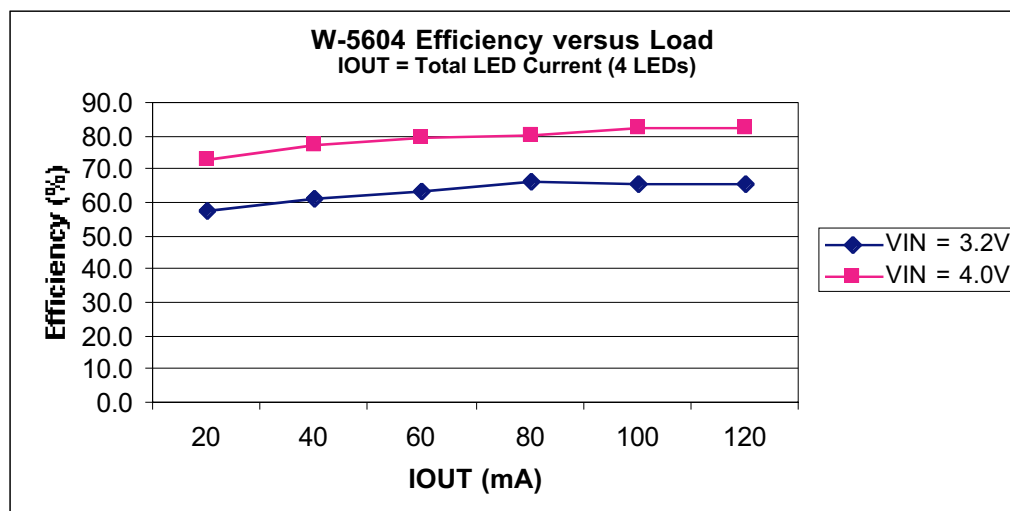

Figure 9. W-5604 Efficiency versus Load

4) Dimming Control

The LED brightness control can be accomplished by using a PWM signal applied to the EN pin, or to the CTR0, CTR1, CTR2 inputs. The other method is to use a variable DC voltage applied through a resistor to RSET pin.

4.1) Dimming using a PWM signal on the Enable or Control pins

The LEDs are turned-off and on at the PWM frequency. The average current changes with the duty cycle and the LED brightness changes accordingly. The peak current value sets the light spectrum.

a) PWM signal applied to the EN pin

- Connect the jumper shunt between Pin #2 and Pin #3 of the J1 connector.
- Apply a pulse signal generator to the GEN/DC (T3) pad; Frequency = 50 Hz - 100 Hz; Amplitude 0V to 2V, VIN = 3.2V.
- Modify the duty cycle between 0% and 100%.
- Observe the average current through LEDs. For 0% duty cycle, the ILED will be off (ILED = 0mA); At the maximum duty cycle, the LED will be driven at the maximum current set by the R7 potentiometer.

Figure 10 shows the total LED current, IOUT, measured with a current probe (CH3) using a PWM signal (aprox. 40% duty cycle) applied to the EN pin (CH1).

Figure 11 shows the W-5604 wake-up from shutdown mode (EN going from "0" to "1"). The device starts in 1x mode and after a delay of 700 us approximately, the W-5604 enters in that operation mode required by load. In this case, with VIN = 3.2V and 4 LEDs driven at 15 mA, the device enter after the start-up period in 1.5x mode. The CH3 waveform shows the input current, IIN, during the wake-up from the shutdown mode.

Due to the start-up period of hundreds of us when the EN signal goes active, the dimming control using the PWM on EN pin requires a slower frequency (i.e. 50Hz - 100 Hz).

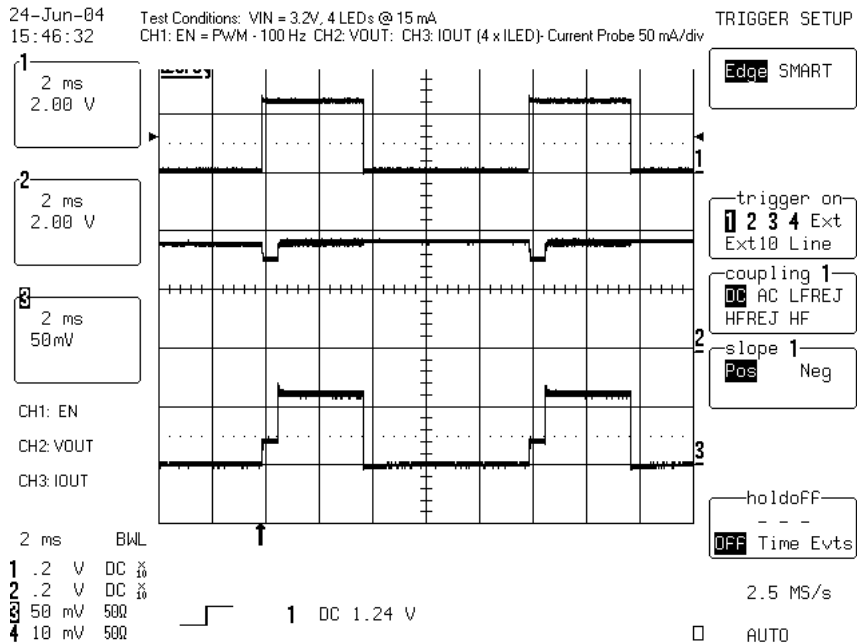

Figure 10. Total LED Current Waveform with PWM on EN pin

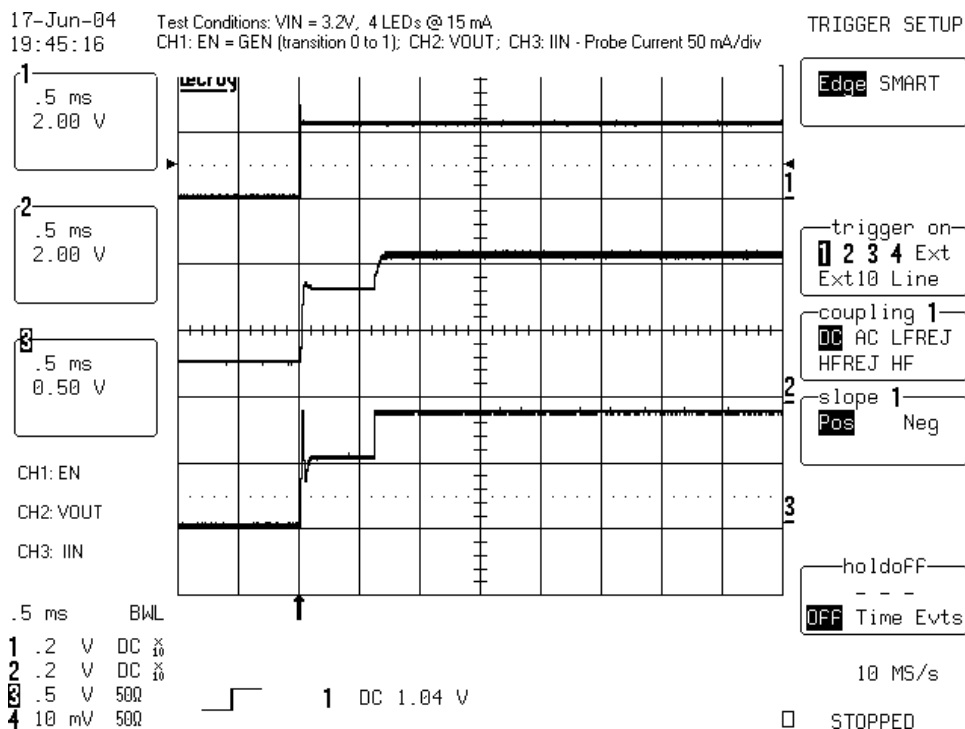

Figure 11. W-5604 Wake-Up from Shutdown Mode (VIN = 3.2V)

b) PWM signal applied to the CTR0 pin

- Connect the jumper shunt between Pin #1 and Pin #2 of the the J1 connector (EN = "1").
- Set the S1 switch: CTR0 = 0, CTR1 = 1, CTR2 = 1 (4 LEDs - ON).
- Connect the jumper shunt between Pin #3 and Pin #4 of the J1 connector (CTRO = GEN = PWM signal).
- Apply a pulse signal generator to the GEN/DC (T3) pad; Frequency = 100 Hz - 1 KHz; Amplitude 0V to 2; VIN = 3.2V.
- Modify the duty cycle between 0% and 100%.
- Observe the average current through LEDs. For 0% duty cycle, the 4 LEDs will be ON, driven at the maximum current set by the R7 potentiometer (ILED = 0mA); At the maximum duty cycle, the LEDs will be OFF (ILED = 0 mA).

Figure 12 shows the total LED current, IOOUT, measured with a current probe (CH3: 50 mA/div) using a PWM signal (30% duty cycle) applied to the CTR0 pin (CH1).

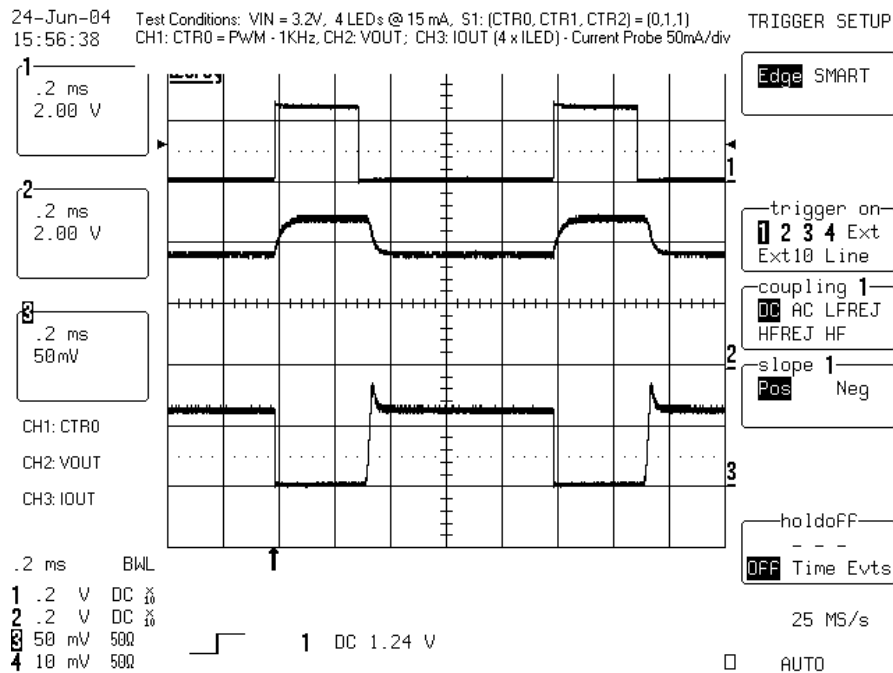

Figure 12. Total LED Current Waveform with PWM on CTR0 pin

4.2) Dimming using a DC voltage applied to the RSET pin

A variable external DC voltage is applied through a serial resistor (R5) to the RSET pin to adjust the LED current. As the DC voltage is increased, the voltage drop on resistor R5 is increased and the voltage drop on RSET (R6 + R7) is decreased, thus the LED current decreases. When the adjustable DC voltage value, V_{DC-var} , is zero, the LED current will be at the maximum value. The R5 in parallel with RSET (R6 + R7) should be equal or less than 15 kohm to limit the maximum ILED value (i.e. ILED max = 30 mA).

The following procedure is an example of LED current dimming with an adjustable DC voltage applied on RSET pin:

- Connect the EN pin to VIN: jumper shunt between Pin #1 and Pin #2 of J1 connector.
- Mount the R5 = 40 Kohm on board
- Connect R5 resistor to the RSET pin using a jumper between Pin #7 and Pin #8 of J1 connector.
- Apply the external variable DC voltage between GEN/DC (T3) and GND (T4). Set $V_{DC-var} = 0V$
- Adjust R7 to set the ILEDmax value current: (i.e. ILED_MAX = 20 mA). Monitor ILED with a current meter inserted on J2 connector.
- Increase the DC voltage value using small steps.
- Observe the ILED current decreases from the ILED MAX (20 mA – previous set) to ILED MIN (0 mA for VMAX = 2.4V).

COPAL ELECTRONICS

NIDEC COPAL ELECTRONICS CORP.
Japan Head Office
Nishi-Shinjuku, Kimuraya Bldg.,
7-5-25 Nishi-Shinjuku, Shinjuku-ku, Tokyo 160-0023
Phone: +81-3-3364-7055
Fax: +81-3-3364-7098
www.copal-electronics.com

Doc. Number: 6037
Revision: A
Issue date: 6/28/04