

W-5636DB1 Evaluation/Demo Board for W-5636 6-Channel Quad-Mode™ LED Driver

Denisa Stefan, Applications Engineer
Cornel Rotaru, Applications Engineer

1. INTRODUCTION

This document describes the W-5636DB1 Evaluation/Demonstration Board for the COPAL ELECTRONICS W-5636 6-Channel Quad-Mode fractional LED driver. The functionality and major parameters of the W-5636 can be evaluated with the W-5636DB1 board.

The W-5636 is a 6-channel charge pump that has been designed to drive with high efficiency up to 6 LEDs connected in parallel. The device can drive three groups of two LEDs. Each group can be configured with independent LED current of up to 32mA max per channel through the 1-wire serial interface. The W-5636 is operating in either 1x mode (LDO), 1.33x, 1.5x, or 2x mode and provides tightly

matched regulated current through the six LED outputs. Each bank of LEDs can be also turned off/on independently through the 1-wire digital interface. Detailed descriptions and electrical characteristics are in the W-5636 data sheet.

2. BOARD HARDWARE

The board contains the W-5636 in a typical application circuit, driving 6 white LEDs. The W-5636 is controlled through the 1-wire serial interface using an 8-bit microcontroller. The user can chose to drive on/off any pair of LEDs or to set the desired LED current through a PC serial interface. The board is powered from an attached 9V battery. The block diagram of the board hardware schematic is shown in Figure 1.

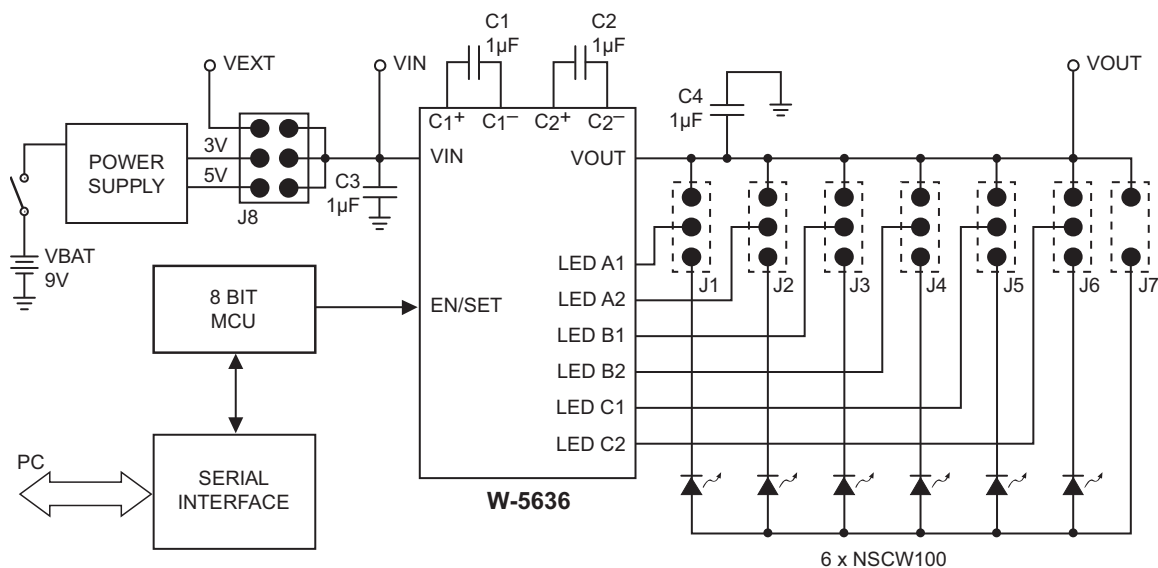

Figure 1. W-5636DB1 Board Block Schematic

The W-5636 input voltage, VIN is supplied on board from a fixed +5V or +3V voltage (internally provided) or from an external voltage applied to the VEXT (T1) pad. The voltage supplied at the VIN input of the W-5636 device can be selected using the jumper options for the J8 connector.

The component placement, top side, for the W-5636DB1 and the board picture are shown in Figure 2. The detailed schematic and the list of components for the W-5636DB1 are shown in the Appendix attached in the end of this document.

The board uses an 8-bit microcontroller, 8051 type. The EN/SET input is controlled on board through the microcontroller when the J9 connector is jumpered between Pin #2 and Pin #3 (jumper shunt between EN/S and INT). The microcontroller provides the pulses on the EN/SET line according to a specific writing protocol for setting the W-5636 internal registers.

The user can also choose to drive the EN/SET input of the W-5636 device with an externally provided signal, if the J9 connector has the jumper between Pin #1 and Pin #2 (jumper shunt between EN/S and EXT). The external signal should be connected to T3/ EXT GEN test point.

The user can connect, or disconnect the W-5636 outputs to the LEDs using the jumper options for J1, J2, J3, J4, J5, J6 and J7 connectors. J1 to J7 header pin connectors can be used to insert a current meter to evaluate the programmed LED current on each channel.

The board is powered when the "POWER" switch is turned ON. The W-5636DB1 boards are populated with six white LEDs (Nichia NSCW100).

3. BOARD OPERATION

3.1 Stand-alone Board

The board can be used as a demonstration board without connection to the PC. As a stand-alone board, when the POWER switch is turned ON, the microcontroller starts executing a routine that sequentially sets different LED current values for each of 3 groups LED output channels. This loop is executed as long as the board is powered.

3.2 W-5636DB1 Board Controlled through the PC Serial Interface

The user can set the desired LED current value for each of W-5636 output channel connecting the W-5636DB1 through a PC serial interface. The W-5636DB1 software provides the user a very friendly graphical interface (GUI) for sending all the commands to drive on/off the LEDs and to program the LEDs current.

The W-5636DB1 software requires the following minimum system configuration:

- Microsoft Windows 98SE or above
- 100K of available hard disc space
- Serial Interface Port

The software is available on the W-5636DB1 software distribution CD-ROM.

The W-5636DB1 software is an executable program ("W-5636EVAL1.exe") which can be run from CD.

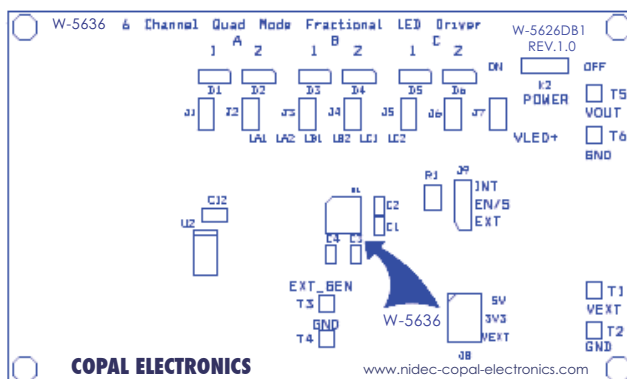

Figure 2. W-5636DB1 Board

The following steps should be followed to control the W-5636DB1 demo board from the PC:

- a) Connect the W-5636DB1 board to the PC serial port through a cable with 9-pin connectors, extender type. (For a limited quantity the connection cable is provided.)
- b) Power the W-5636DB1 board: Turn the "POWER" switch ON. (The board should be powered when you start the program; otherwise an error message will be displayed).
- c) Run the "W-5636EVAL1.exe" program from the directory where the software was installed.
- d) The W-5636 Evaluation Board user interface window opens (Figure 3). When the program starts, the W-5636 will be in the enabled state (EN/SET input is set high). The user may choose to disable the device by pressing the ENABLE/DISABLE button which has a toggle function.
- e) After the device is enabled, the user can write into the REGISTER_1 to set the current mode (IMODE) and activate the corresponding LED output channels. Figure 4 shows all the LED channels active and current mode set to high current range (up to 32mA) selected. The current for each channel is set at the minimum value (=2.0mA).

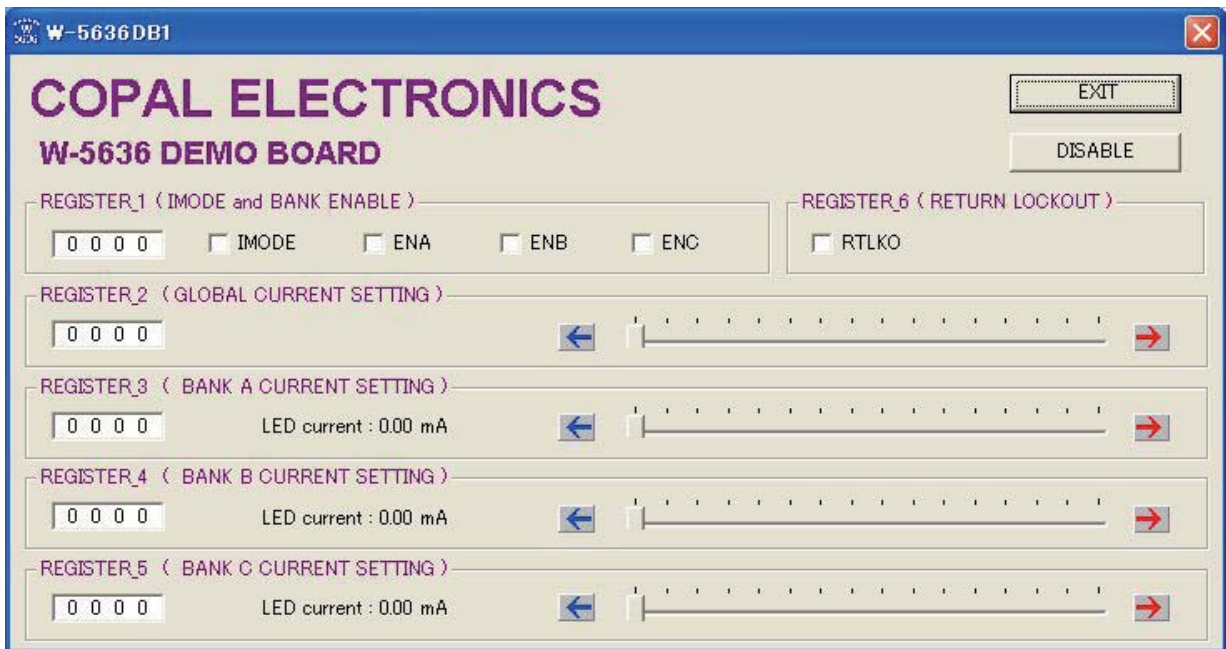

Figure 3. W-5636 Board Software Interface Window (Start Window)

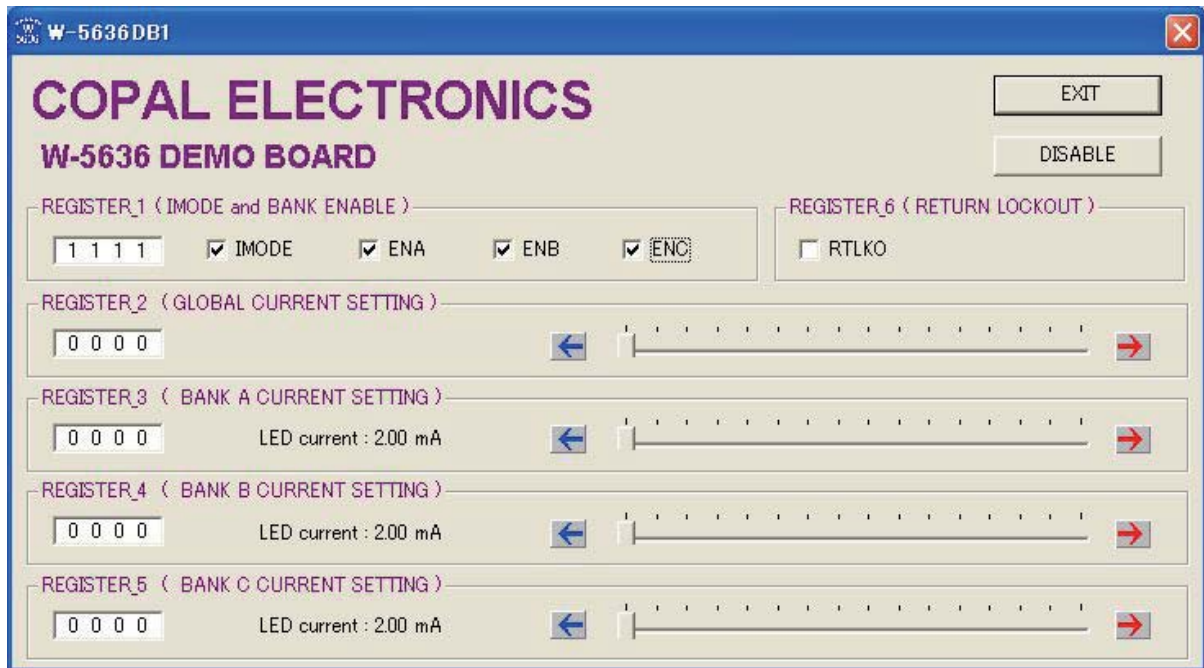

Figure 4. W-5636 with all channels enabled (IMODE=1) and ILED set to min value

Using the W-5636DB1 software, the user can access all the internal registers of the W-5636:

- Register_1: sets the current mode (IMODE=0: ILED<4mA; IMODE=1: ILED<32mA) and selects the LED bank (A, B, C)
- Register_2: sets the same LED current for all 6 channels (Global Current Setting)
- Register_3: sets the LED current for group A (LEDA1, LEDA2)
- Register_4: sets the LED current for group B (LEDB1, LEDB2)
- Register_5: sets the LED current for group C (LEDC1, LEDC2)
- Register_6: controls the return lockout bit (RTLKO); when RTLKO=1, the charge pump cannot automatically return to 1x mode of operation.

Note: When using the software interface for programming high LED currents, the selection of VEXT is recommended: J8 connector with jumper shunt on VEXT position; VEXT voltage applied at T1 test point (T2=GND).

The user can set the current for any group, by writing the associated register with the desired value. The current can be set in 16 steps between 2.0mA and 32mA for IMODE=1, or between 0mA and 3.75mA for IMODE=0. These 16 steps correspond to the binary registers values of 0000 to 1111. The user can change the LED current value by writing the corresponding binary value in the associated register. The current value can be also changed moving the cursor or/and pressing the arrows buttons on the slider associated to each register.

As an example, Figure 5 shows all the channels enabled and the LED currents set to 10mA (Group A), 16mA (Group B) and 32mA (Group C).

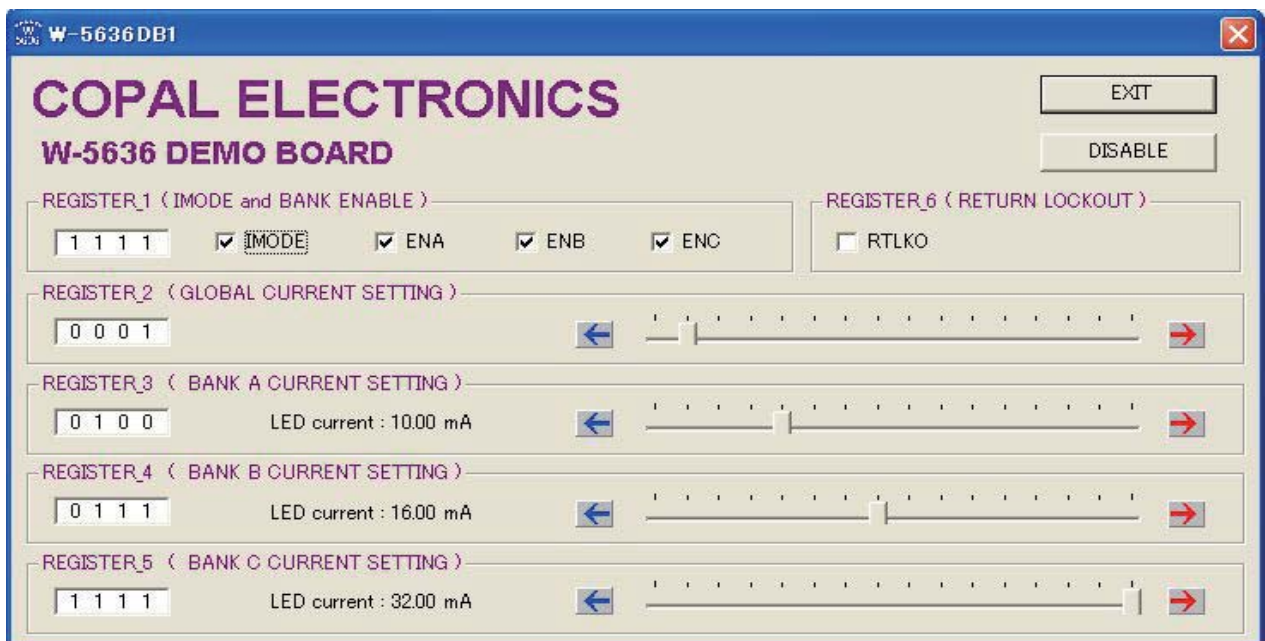

Figure 5. W-5636 with LED current set independently for each LED group

Table 1. W-5636DB1 Board List of Components

Name	Manufacturer	Description	Part Number	Units
U1	COPAL ELECTRONICS	6-Channel Quad-Mode LED Driver, TQFN16 3x3mm	W-5636HV3	1
U2	Philips Semiconductor	8- bit flash microcontroller TSSOP20	P89LPC922FDH	1
U3	Intersil	RS-232 Transmitter/receiver, SOIC16 Narrow	ICL3232ECBN	1
U4	National Semiconductor	3.3V, Low Dropout Voltage Regulator, SOT223	LM3940-3.3	1
U5	National Semiconductor	5V Voltage Regulator, 1A, SOT223	LM340MP-5.0	1
C1, C2, C3, C4, C12	AVX	Ceramic Capacitor 1uF / 10V, 10%, X5R, Size 0603	0603ZD105KAT2A	5
C5, C6, C7, C8, C9, C10, C11	AVX	Ceramic Capacitor 0.1uF / 10V, 10%, X7R, Size 0805	0805ZC104KAT2A	7
C13, C14	AVX	Ceramic Capacitor 22pF / 100V, 5% COG, Size 1206	12061A220JAT2A	2
C15	AVX	Tantalum 10uF / 10V, 10%, Low ESR	TPSA106K010R1800	1
R1	Yageo	SMT Resistor 1/8W, 180Kohm, 1%, Size 0805	Digi-Key 311-180KCCT-ND	1
D1 to D6	Nichia	White LED, SMT	NSCW100	6
J1 to J6, J9	MMM	3-pin Header Connector, 0.1", Single Strip	2303-6211TG	7
J7	MMM	2-pin Header Connector, 0.1", Single Strip	2302-6211TG	1
J8	MMM	6-pin Header Connector, 0.1", Double Strip	2308-6221TG	1
K2	ITT Cannon	Slide switch	L102-01-1-MS-02-Q2	1
X1	Vishay	Crystal 11.0592 MHz	XT9SNLANA11M0592	1
	Specialty Electronics	Jumper Shunts	2JM-G	9
PP1	ITT Cannon	D-Sub-Plug 9-Pole Solder Pin	DE-9P	1
T1 to T6	Mil-Max	Pin Receptacle	#0149-0-15-01-30-14-04-0	6
BTH	Keystone	Battery Holder 1x 9V	BHR1294	1

REVISION HISTORY

Date	Rev.	Reason
12/19/2006	A	Initial Issue

NIDEC COPAL ELECTRONICS CORP. MAKES NO WARRANTY, REPRESENTATION OR GUARANTEE, EXPRESS OR IMPLIED, REGARDING THE SUITABILITY OF ITS PRODUCTS FOR ANY PARTICULAR PURPOSE, NOR THAT THE USE OF ITS PRODUCTS WILL NOT INFRINGE ITS INTELLECTUAL PROPERTY RIGHTS OR THE RIGHTS OF THIRD PARTIES WITH RESPECT TO ANY PARTICULAR USE OR APPLICATION AND SPECIFICALLY DISCLAIMS ANY AND ALL LIABILITY ARISING OUT OF ANY SUCH USE OR APPLICATION, INCLUDING BUT NOT LIMITED TO, CONSEQUENTIAL OR INCIDENTAL DAMAGES.

NIDEC COPAL ELECTRONICS CORP. products are not designed, intended, or authorized for use as components in systems intended for surgical implant into the body, or other applications intended to support or sustain life, or for any other application in which the failure of the NIDEC COPAL ELECTRONICS CORP. product could create a situation where personal injury or death may occur.

NIDEC COPAL ELECTRONICS CORP. reserves the right to make changes to or discontinue any product or service described herein without notice. Products with data sheets labeled "Advance Information" or "Preliminary" and other products described herein may not be in production or offered for sale.

NIDEC COPAL ELECTRONICS CORP. advises customers to obtain the current version of the relevant product information before placing orders. Circuit diagrams illustrate typical semiconductor applications and may not be complete.

COPAL ELECTRONICS

NIDEC COPAL ELECTRONICS CORP.
Japan Head Office
Nishi-Shinjuku, Kimuraya Bldg.,
7-5-25 Nishi-Shinjuku, Shinjuku-ku, Tokyo 160-0023
Phone: +81-3-3364-7055
Fax: +81-3-3364-7098
www.nidec-copal-electronics.com

Document No: 6052
Revision: A
Issue date: 12/19/06