

10 Channel Automotive LED Display Driver

FEATURES

- Automotive “load dump” protection (40V)
- 10 independent LED channels
- Up to 50mA output per channel
- Overvoltage detection at 19V
- Serial interface for channel programming
- Daisy chain output for multi-driver cascading
- LED blanking control
- Operating temperature from -40°C to +125°C
- 20-pin SOIC package

APPLICATIONS

- Automotive lighting
- White and other color high brightness LEDs
- Multi-color high-brightness LED cluster displays
- General LED lighting

ORDERING INFORMATION

Part Number	Package	Quantity per Reel	Package Marking
W-510W	SOIC-20 Lead free	1000	W-510W

For Ordering Information details, see page 10.

TYPICAL APPLICATION CIRCUIT

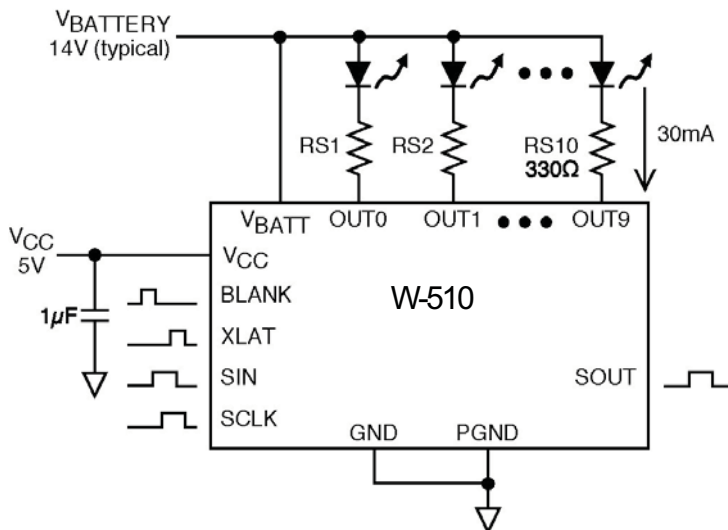

PRODUCT DESCRIPTION

The W-510 is a 10-channel LED driver for automotive and other lighting applications. All LED output channels are driven from a low on-resistance open-drain High Voltage CMOS Nch-FETs and are fully compliant with “Load Dump” transients of up to 40 volts. The LED bias current of each channel can be set independently using an external series ballast resistor, making the device ideal for multi-color instrumentation displays.

A high-speed serial interface (suitable with both 3.3 volt and 5 volt systems) feeding a 10 bit shift register is used to program the desired state (on/off) of each channel. The device offers a blanking control pin (BLANK) which can be used to disable all channels on demand. A serial output data pin (SOUT) is provided to daisy-chain devices in large cluster LED applications

During initial power up all channels are reset and cleared via an under-voltage lock out (UVLO) detector and for added protection all channels are disabled in the event of a battery over-voltage condition (19 volts or more).

PIN DIAGRAM

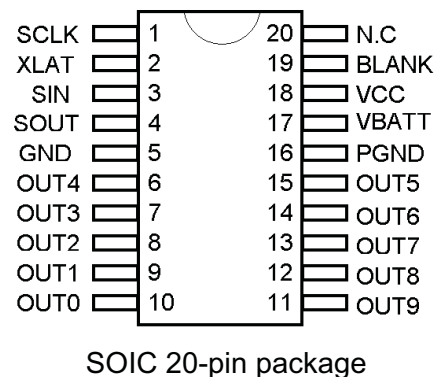

ABSOLUTE MAXIMUM RATINGS

Parameter	Rating	Unit
VCC voltage	7	V
Input voltage range (SIN, SCLK, BLANK, XLAT)	-0.3V to VCC+0.3V	V
SOUT voltage range	-0.3V to VCC+0.3V	V
Peak OUT0 to OUT9 voltage	40	V
VBATT input voltage	40	V
DC output current on OUT0 to OUT9	70	mA
Storage Temperature Range	-55 to +160	°C
Operating Junction Temperature Range	-40 to +150	°C
Lead Soldering Temperature (10sec.)	300	°C
ESD Rating: Low Voltage Pins Human Body Model Machine Model	3000 300	V
ESD Rating: VBATT, OUT[0:9] pins Human Body Model Machine Model	1000 100	V

RECOMMENDED OPERATING CONDITIONS

Parameter	Range	Unit
VCC	3.0 to 5.5	V
Voltage applied to OUT0 to OUT9	9 to 17	V
Output current on OUT0 to OUT9	0 to 50	mA
Ambient Temperature Range	-40 to +125	°C

ELECTRICAL OPERATING CHARACTERISTICS

DC Characteristics VCC = 5.0V, -40°C ≤ T_A ≤ 125 °C, over recommended operating conditions unless specified otherwise.

Symbol	Name	Conditions	Min	Typ	Max	Units
I _{STBY}	Standby Quiescent Current	Static input signal. All outputs turned off.		1	10	μA
V _{OV}	VBATT Over Voltage Protection Trigger threshold		17	19	21	V
V _{UVLO}	VCC Under Voltage Lockout Trigger threshold			1.7	2.5	V
R _{SW}	Switch on resistance for OUT0 to OUT9	I _{O(n)} = 30mA	2	5	12	Ω
I _{O(n)LKG}	OUT0 to OUT9 Output Switch Leakage	V _{OUT(n)} = 15V		0.1	10	μA
I _{XLAT}	XLAT Internal Pull-down current	XLAT = V _{CC} XLAT = 0.3V	4 1	10 3	30 6	μA
I _{BLANK}	BLANK Internal Pull-up current	BLANK = 0V BLANK = V _{CC} - 0.3V	4 1	10 3	30 6	μA
V _{IH} V _{IL}	Logic high input voltage Logic low input voltage				0.7V _{CC}	V
I _{IL}	Logic Input leakage current (SCLK, SIN)	V _I = V _{CC} or GND	-5	0	5	μA
V _{OH} V _{OL}	SOUT logic high output voltage SOUT logic low output voltage	I _{OH} = -1mA I _{OL} = 1mA	V _{CC} - 0.3V		0.3	V

ELECTRICAL OPERATING CHARACTERISTICS

Switching Characteristics $V_{CC} = 5.0V$, $-40^{\circ}C \leq T_A \leq 125^{\circ}C$, over recommended operating conditions unless specified otherwise.

Symbol	Name	Conditions	Min	Typ	Max	Units
SCLK						
f_{SCLK}	SCLK Clock Frequency				10	MHz
$t_{wh/wl}$	SCLK Pulse width	High or Low	30			ns
SIN						
t_{su}	Setup time SIN to SCLK		10			ns
t_h	Hold time SIN to SCLK		10			ns
XLAT						
t_w	XLAT Pulse width	SIN to SCLK	20			ns
t_h	Hold time SCLK to XLAT		20			ns
t_r	SOUT rise time (10% to 90%)	$C_L = 15pF$		20		ns
t_f	SOUT fall time (90% to 10%)	$C_L = 15pF$		15		ns
t_{pd}	Propagation delay time	Blank \uparrow to OUT(n)		25		ns
t_{pd}	Propagation delay time	Blank \downarrow to OUT(n)		25		ns
t_{pd}	Propagation delay time	SCLK to SOUT		25		ns

All logic inputs contain Schmitt trigger inputs.

BLOCK DIAGRAM

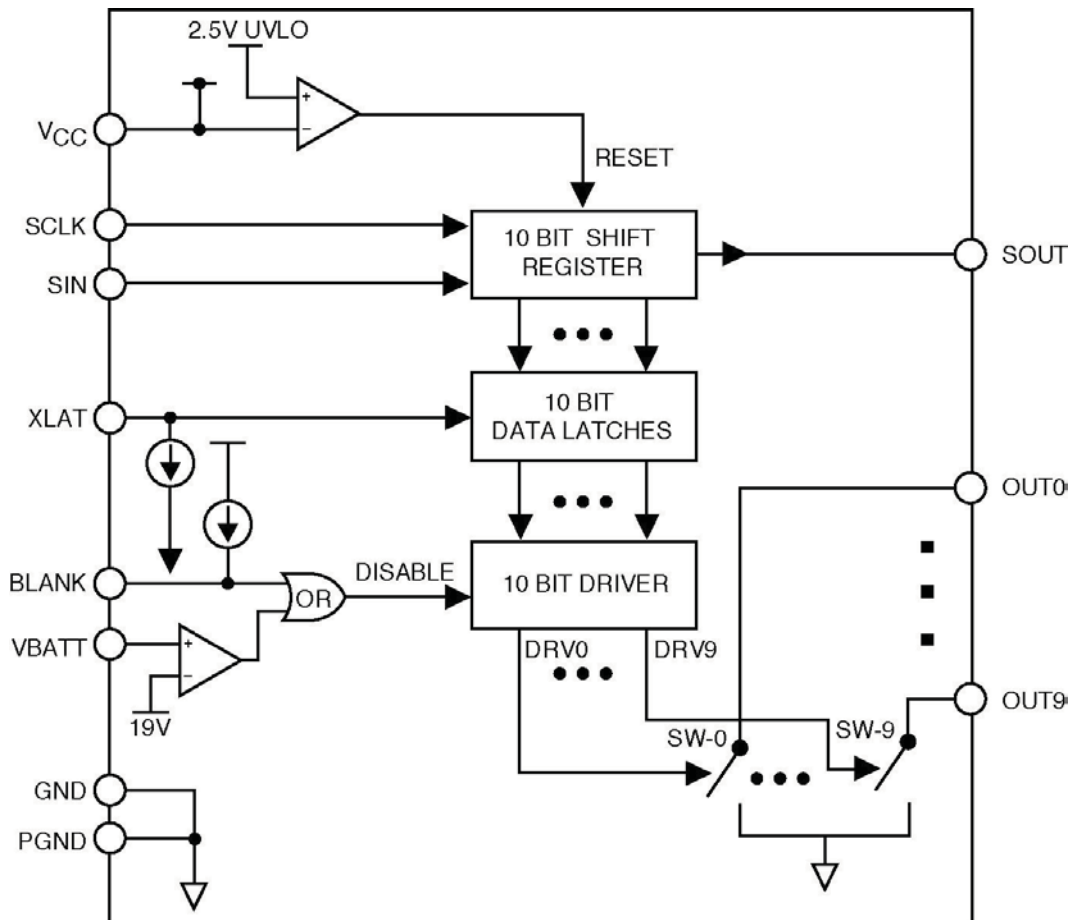

PIN DESCRIPTIONS

VCC is the supply input for the internal logic and is compatible with both 3.3V and 5V systems. The logic is held in a reset state until VCC exceeds 2.5V. It is recommended that a small bypass ceramic capacitor (1uF) be placed between VCC and GND pins on the device.

SIN is the CMOS logic pin for delivering the serial input data stream into the internal 10-bit shift register. The most recent or last data value in the serial stream is used to configure the state of output channel “zero” (OUT0). During the initial power up sequence all contents of the shift register are reset and cleared to zero.

SCLK is the CMOS logic pin used to clock the internal shift register. On each rising edge of clock, the serial data will advance through one stage of the shift register.

XLAT is the CMOS logic input used to transfer data from the 10-bit shift register into the output channel latches. An internal pull-down current of 10 microampere is present on this pin. When XLAT is low, the state of each output channel remains unchanged. When XLAT is driven high, the contents of the shift register appear at their respective output channels. An external pull-up resistance of 10kΩ or less is adequate for logic high.

PGND, GND pins should be connected to the ground on the PCB.

BLANK is the CMOS logic input (active high) used to temporarily disable all outputs. An internal pull-up current of 10 microampere is present on this pin. The BLANK pin must be driven to a logic low in order for channel outputs to resume normal operation. An external pull-down resistance of 10kΩ or less is adequate for logic low.

SOUT is the CMOS logic output used for daisy chain applications. The serial output data stream is fed from the last stage of the internal 10-bit shift register. On each rising edge of the clock, the SOUT value will be updated. The data value present on this pin is identical to the data value being used for configuring the state of output channel nine (OUT9). At initial power up, the SOUT data stream will contain all zeroes until the shift register has been fully loaded.

VBATT input monitors the battery voltage. If an over-voltage, above 19V typical, is detected, all outputs are disabled. Upon conclusion of the over-voltage condition, all outputs resume normal operation. The current drawn by the VBATT pin is less than 1 microampere during normal operation.

OUT0-OUT9 are the ten LED outputs connected internally to the switch N-channel FETs. They sink currents up to 50mA per channel and can withstand transients up to 40V compatible with automotive “load dump”. The output on-resistance is 5Ω, and the off-resistance is 5MΩ.

PIN TABLE

Pin Number	Pin Name	Description/Function
1	SCLK	Clock input for the data shift register.
2	XLAT	Control input for the data latch.
3	SIN	Serial data input.
4	SOUT	Serial data output.
5	GND	Ground.
6-10	OUT4 - OUT0	Open drain outputs.
11-15	OUT9 - OUT5	Open drain outputs.
16	PGND	Ground for LED driver outputs.
17	VBATT	Battery sense input.
18	VCC	Power supply voltage for the logic
19	BLANK	Blank input. When BLANK is high, all the output drivers are turned off.
20	N.C.	No connect.

TYPICAL CHARACTERISTICS

VCC = 5V, VBATT = 14V, T_{AMB} = 25°C, unless otherwise specified.

VBATT Overvoltage Detection
Amplitude between 16V and 26V

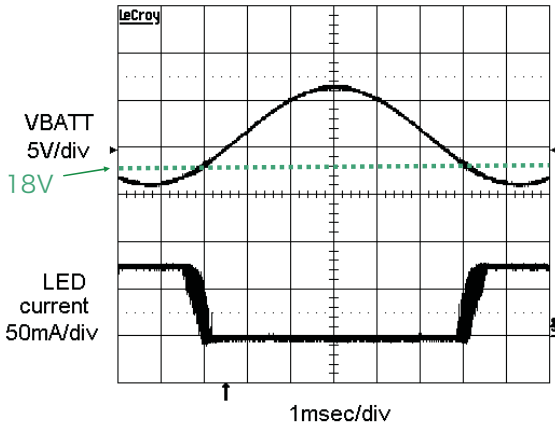

BLANK and Output waveform

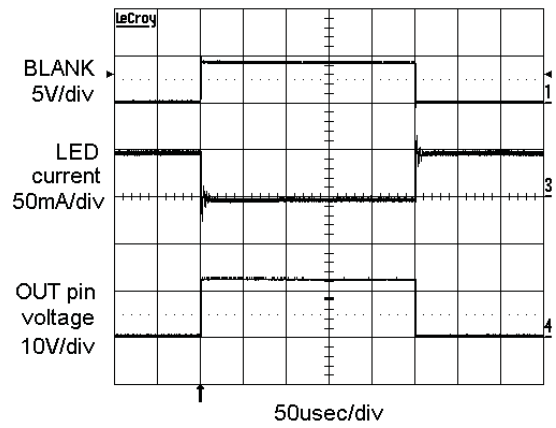

XLAT pull-down Current vs. Input Voltage

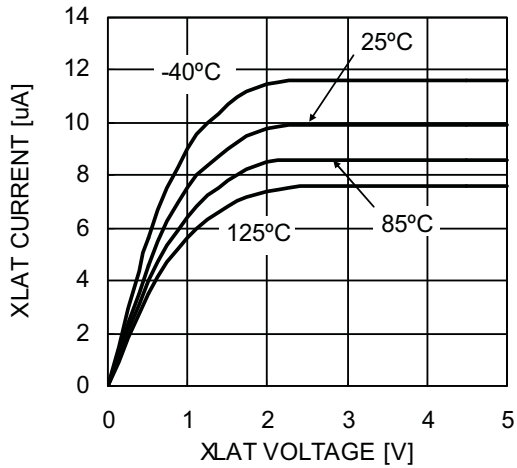

BLANK pull-up Current vs. Input Voltage

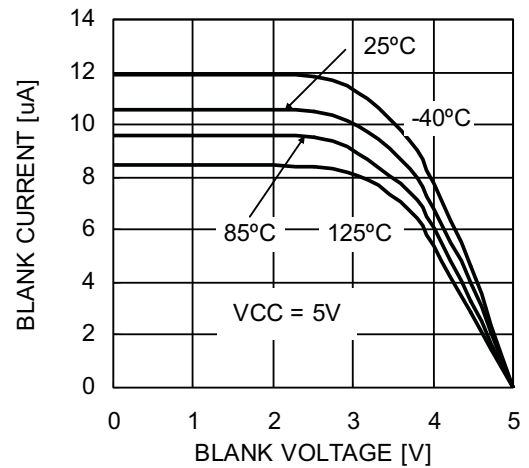

VBATT Load Dump

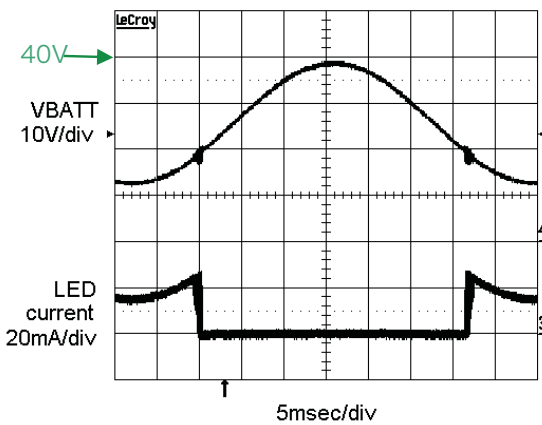

Switch On-resistance vs. VCC

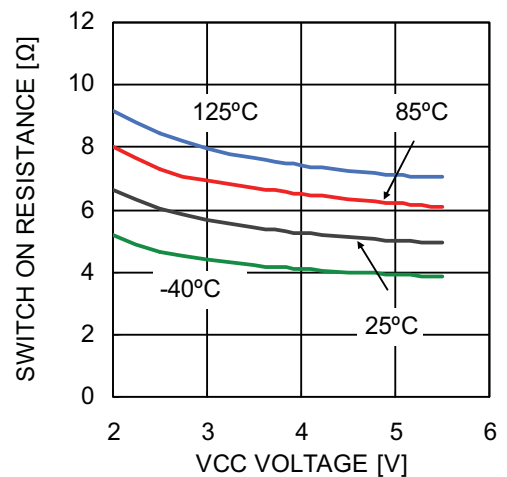

TYPICAL CHARACTERISTICS

VCC = 5V, VBATT = 14V, T_{AMB} = 25°C, unless otherwise specified.

Output Channel Leakage vs. Bias Voltage

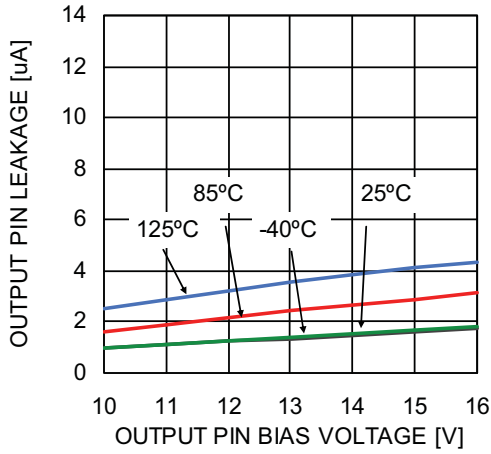

Quiescent Current vs. Temperature

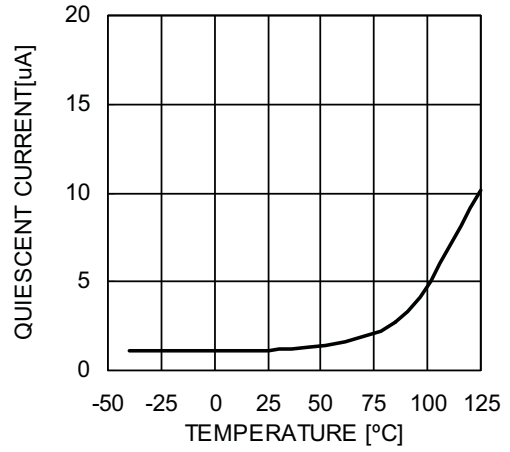

VBATT Overvoltage Detection vs. Temperature

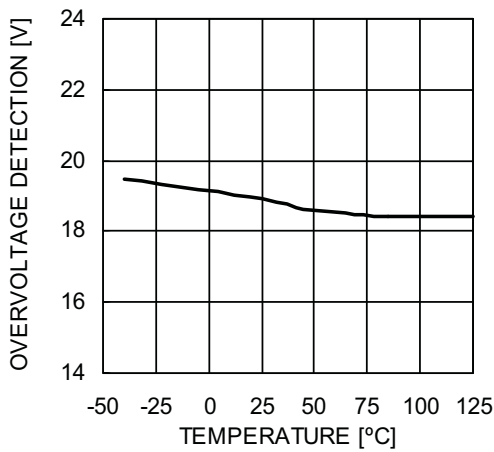

VCC Undervoltage Lockout vs. Temperature

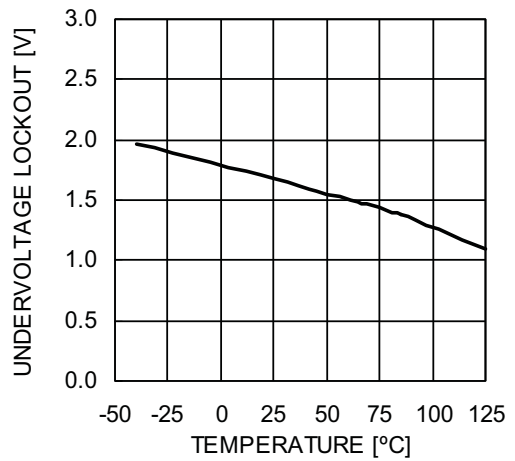

FUNCTIONAL DESCRIPTION

The W-510 implements a 10-bit serial-in shift register for storing the setting of the ten outputs. Serial input data SIN are clocked into the shift register on the rising edge of the clock. At the 10th clock pulse, the first data bit entered is outputted from the shift register to SOUT. The following clock pulses will output the following data bits onto SOUT. The output data pattern replicates the input data stream with a delay of ten clock pulses.

The 10-bit data pattern present in the shift register is stored in the 10-bit data latch when

the latch signal XLAT is logic high. When XLAT transitions to logic low, data are latched and stay unchanged for as long as XLAT remains low. The last serial input data corresponds to OUT0. The serial input data that was received 10 clock pulse ago is stored in OUT9. When the BLANK input is logic high, all the output switches are in the off state. If the BLANK input is low, the 10-bit data latches control the 10 output switches. A data bit value of zero keeps the switch off. A data bit value of one keeps the switch on.

Serial to Parallel Shift Register

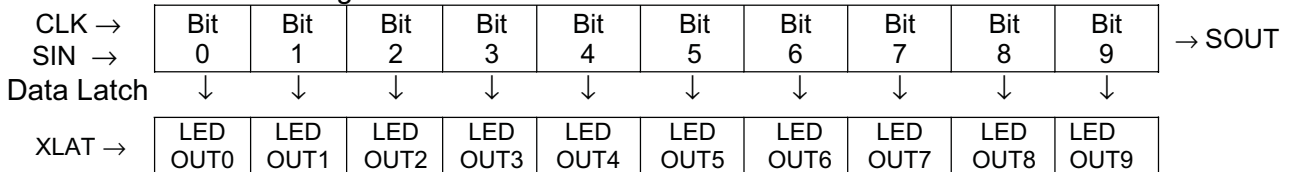

TIMING DIAGRAM

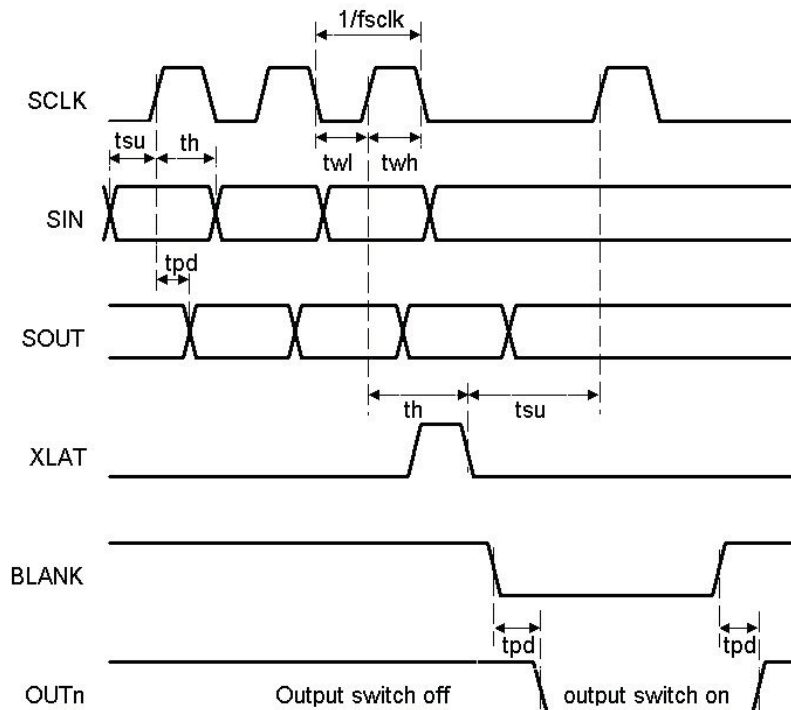

APPLICATION INFORMATION

For applications with a large number of LEDs, several W-510 drivers can be daisy chained. The serial data output pin (SOUT) of the first driver is connected to the second driver data input pin (SIN). This sequence is repeated until the last driver is linked. All drivers are controlled by the same clock signal. Figure 1 shows an

example with three W-510 devices driving a total of 30 LEDs in parallel. The controller transmits the serial data sequentially through the W-510 devices. For N drivers connected in cascade, after 10 x N clock pulses, the data are latched with one single XLAT transition.

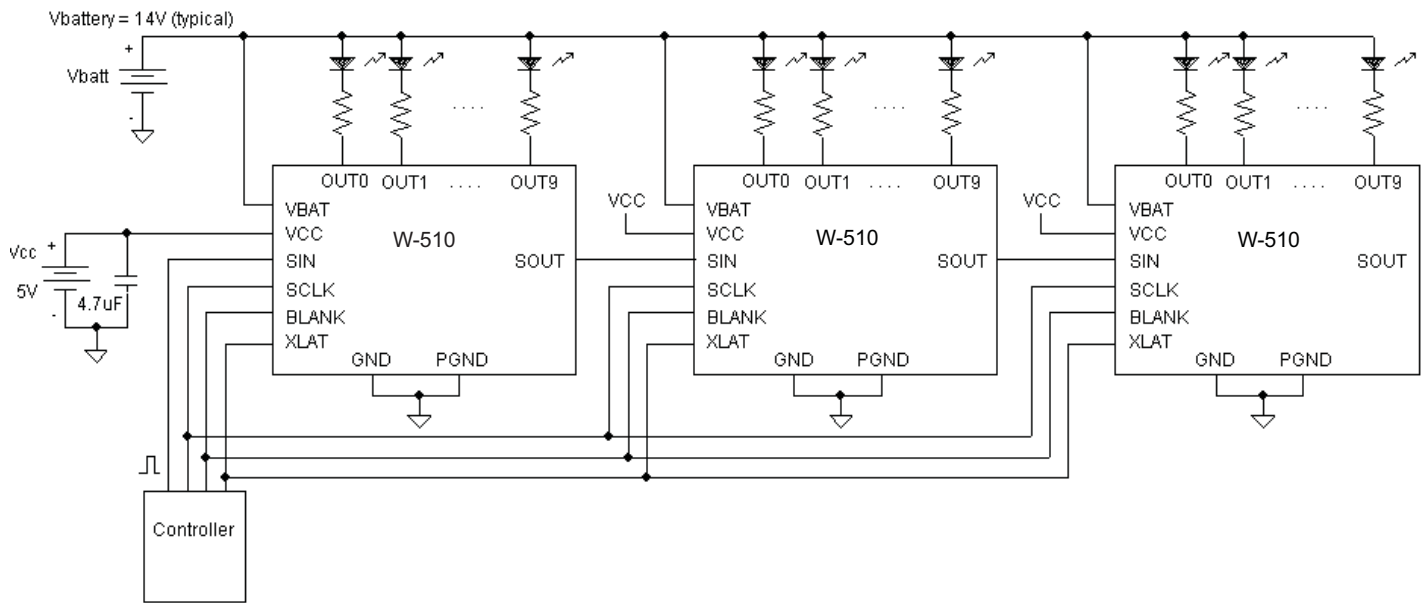
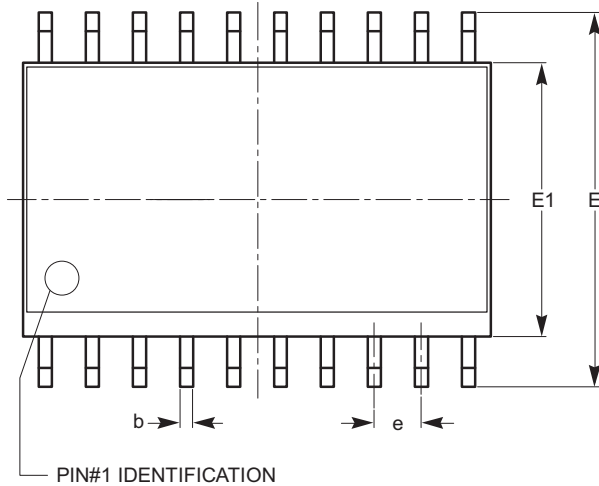

Figure 1. Daisy Chain Application Diagram

PACKAGE OUTLINE DRAWING

SOIC 20-Lead 300mils (W)



TOP VIEW

SYMBOL	MIN	NOM	MAX
A	2.36	2.49	2.64
A1	0.10		0.30
A2	2.05		2.55
b	0.31	0.41	0.51
c	0.20	0.27	0.33
D	12.60	12.80	13.00
E	10.01	10.30	10.64
E1	7.40	7.50	7.60
e	1.27 BSC		
h	0.25		0.75
L	0.40	0.81	1.27
θ	0°		8°
$\theta 1$	5°		15°

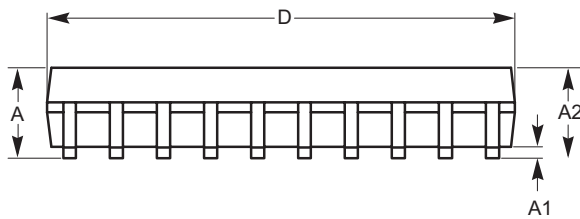

SIDE VIEW

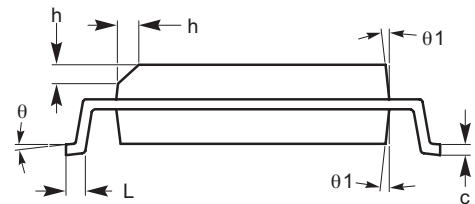

END VIEW

Notes:

- (1) All dimensions are in millimeters. Angles in degrees.
- (2) Complies with JEDEC MS-013.

EXAMPLE OF ORDERING INFORMATION

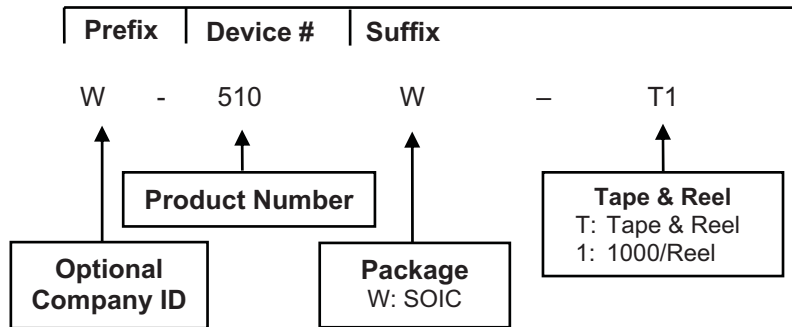

Notes:

- (1) All packages are RoHS-compliant (Lead-free, Halogen-free).
- (2) The device used in the above example is a W-510W-T1 (SOIC, Tape & Reel).

REVISION HISTORY

Date	Revision	Reason
05/05/2005	00	Initial issue
08/22/2007	1	Update Ordering Information Update Package Outline Drawing Add Example of Ordering Information

NIDEC COPAL ELECTRONICS CORP. MAKES NO WARRANTY, REPRESENTATION OR GUARANTEE, EXPRESS OR IMPLIED, REGARDING THE SUITABILITY OF ITS PRODUCTS FOR ANY PARTICULAR PURPOSE, NOR THAT THE USE OF ITS PRODUCTS WILL NOT INFRINGE ITS INTELLECTUAL PROPERTY RIGHTS OR THE RIGHTS OF THIRD PARTIES WITH RESPECT TO ANY PARTICULAR USE OR APPLICATION AND SPECIFICALLY DISCLAIMS ANY AND ALL LIABILITY ARISING OUT OF ANY SUCH USE OR APPLICATION, INCLUDING BUT NOT LIMITED TO, CONSEQUENTIAL OR INCIDENTAL DAMAGES.

NIDEC COPAL ELECTRONICS CORP. products are not designed, intended, or authorized for use as components in systems intended for surgical implant into the body, or other applications intended to support or sustain life, or for any other application in which the failure of the NIDEC COPAL ELECTRONICS CORP. product could create a situation where personal injury or death may occur.

NIDEC COPAL ELECTRONICS CORP. reserves the right to make changes to or discontinue any product or service described herein without notice. Products with data sheets labeled "Advance Information" or "Preliminary" and other products described herein may not be in production or offered for sale.

NIDEC COPAL ELECTRONICS CORP. advises customers to obtain the current version of the relevant product information before placing orders. Circuit diagrams illustrate typical semiconductor applications and may not be complete.

COPAL ELECTRONICS

NIDEC COPAL ELECTRONICS CORP.
Japan Head Office
Nishi-Shinjuku, Kimuraya Bldg.,
7-5-25 Nishi-Shinjuku, Shinjuku-ku, Tokyo 160-0023
Phone: +81-3-3364-7055
Fax: +81-3-3364-7098
www.nidec-copal-electronics.com

Document No.: 25087
Revision: Rev. 1
Issue date: 08/22/07