

CMOS White LED Driver

**HALOGEN FREE
LEAD FREE**

FEATURES

- Low quiescent ground current (0.5mA typical)
- Power efficiency over 80%
- Compatible pinout with LT1932
- Adjustable output current (up to 40mA)
- High frequency 1.2MHz operation
- Input voltage operation down to 2.0V
- Low resistance (0.5Ω) high voltage power switch
- Drives up to 4 White LEDs in series
- Shutdown current less than 1μA
- Load fault protection against open-circuits
- Low value external components
- Low profile (1mm) TSOT-23 6-lead package

APPLICATION

- Color LCD and keypad backlighting
- Cellular phones
- Handheld terminals
- Digital cameras
- PDAs/Games
- Portable MP3 players

For Ordering Information details, see page 14.

DESCRIPTION

The W-52 is a DC/DC step up converter that delivers a regulated output current. Operation at a constant switching frequency of 1.2MHz allows the device to be used with very small value external inductor and ceramic capacitors.

The W-52 is targeted to drive multiple white light-emitting diodes (LEDs) connected in series and provides the necessary regulated current to control the brightness and the color purity. An external resistor R_{SET} controls the output current level. LED currents of up to 40mA can be supported over a wide range of input supply voltages from 2V to 7V, making the device ideal for battery-powered applications.

A high voltage output stage allows up to 4 White LEDs to be driven in series. Series drive provides inherent current matching.

LED dimming can be done by using a DC voltage, a logic signal, or a pulse width modulation (PWM) signal. The shutdown input pin allows the device to be placed in power-down mode with “near zero” quiescent current.

In addition to overcurrent limiting protection, the device also includes detection circuitry to ensure protection against open-circuit load fault conditions.

The device is available in a low profile (1mm max height) 6-lead TSOT-23 package.

TYPICAL APPLICATION CIRCUIT

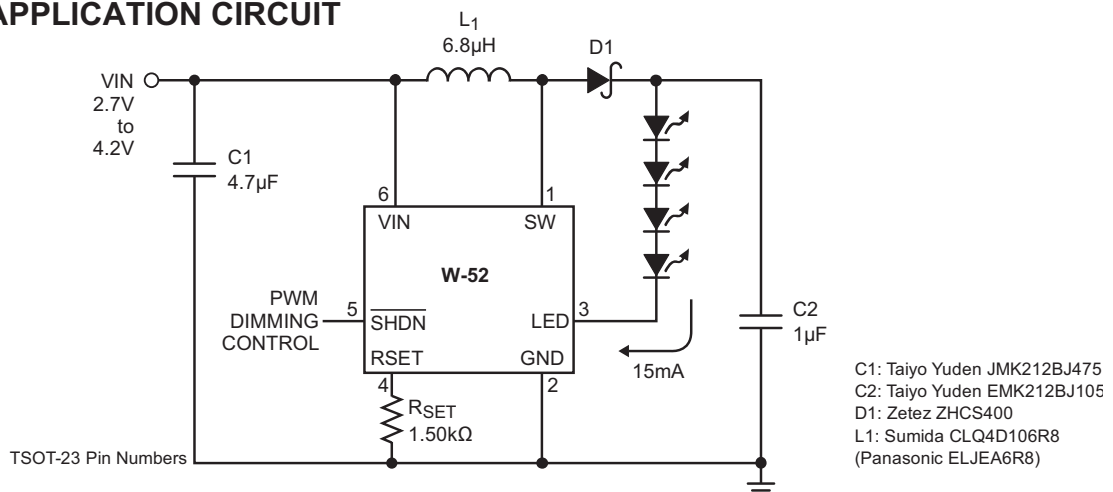
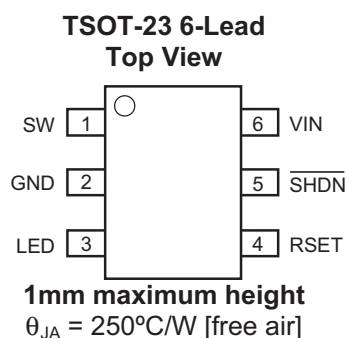

Figure 1. Li-Ion Driver for Four High-Brightness White LEDs

ORDERING INFORMATION

Part Number	Package	Reel Quantity	Package Marking Code
W-52TDI-T3	TSOT23-6	3000	LL

PIN CONFIGURATION



PIN DESCRIPTION

Pin Number	Name	Function
1	SW	Switch pin. This is the drain of the internal power switch. For minimum EMI, minimize the trace area connected to this pin.
2	GND	Ground pin. Connect pin 2 to ground.
3	LED	LED (cathode) connection pin.
4	RSET	RESET pin. A resistor connected from pin 4 to ground sets the LED current. This pin is also used to dim the LEDs.
5	$\overline{\text{SHDN}}$	Shutdown pin.
6	VIN	Input supply pin. This pin should be bypassed with a capacitor to ground. A 4.7 μF capacitor mounted close to the pin is recommended.

ABSOLUTE MAXIMUM RATINGS ⁽¹⁾

Parameter	Rating	Unit
V _{IN} , LED, SHDN voltage	8	V
SW voltage	20	V
RSET voltage	1	V
Storage Temperature Range	-65 to +150	°C
Junction Temperature	125	°C
Lead Soldering Temperature (10 secs)	300	°C
ESD Rating – Human Body Model	2000	V

RECOMMENDED OPERATING CONDITIONS

Parameter	Range	Unit
V _{IN}	2 to 7	V
Ambient Temperature Range	-40 to +85	°C
Inductor L1	6.8 ±20% typical	μH
Input Capacitor C1	4.7 ±20% typical	μF
Output Capacitor C2	1.0 ±20% typical	μF
I _{LED} with 1 to 4 LEDs in series	0 to 20	mA

Typical application circuit with external components is shown on page 1.

ELECTRICAL OPERATING CHARACTERISTICS

Over recommended operating conditions unless otherwise specified. T_A = 25°C, V_{IN} = 2V and V_{SHDN} = 1.2V.

Symbol	Parameter	Conditions	Min	Typ	Max	Unit
I _Q	Quiescent Current	V _{RSET} = 0.2V		0.5	0.7	mA
I _{GND}	Ground Current in Shutdown	V _{SHDN} = 0V		0.05	1	μA
V _{LED}	LED Pin Voltage	V _{IN} < V _{OUT} , I _{LED} = 15mA		120	180	mV
I _{LED}	LED Current Adjust Range		5		40	mA
I _{LED}	Programmed LED Current	R _{SET} = 562Ω	33	38	45	mA
		R _{SET} = 750Ω	25	30	36	
		R _{SET} = 1.5kΩ	12.5	15	17.5	
		R _{SET} = 4.53kΩ		5		
I _{LED}	LED Pin Current Temperature Coefficient	I _{LED} = 15mA		-0.01		mA/°C
V _{RSET}	RSET Pin Voltage	R _{SET} = 1.5kΩ		100		mV
	Shutdown Pin Logic High Level		0.85			V
	Shutdown Pin Logic Low Level				0.25	V
f _{SW}	Boost Converter Frequency		0.8	1.2	1.6	MHz
I _{SWL}	Switch Current Limit		400	550	780	mA
R _{SW}	Switch Resistance	V _{IN} = 2V, I _{SW} = 100mA		0.7	1.2	Ω
		V _{IN} = 3V, I _{SW} = 100mA		0.5	0.9	Ω
	Switch Leakage Current	Switch Off, V _{SW} = 5V		0.01	5	μA
	Efficiency	Components shown on Figure 1		83		%

Notes:

(1) These are stress ratings only and functional operation is not implied. Exposure to absolute maximum ratings for prolonged time periods may affect device reliability. All voltages are with respect to ground.

TYPICAL CHARACTERISTICS

$V_{IN} = 3.6V$, $T_{AMB} = 25^{\circ}C$, $C_{IN} = 4.7\mu F$, $C_{OUT} = 1\mu F$, $L = 6.8\mu H$, unless otherwise specified.

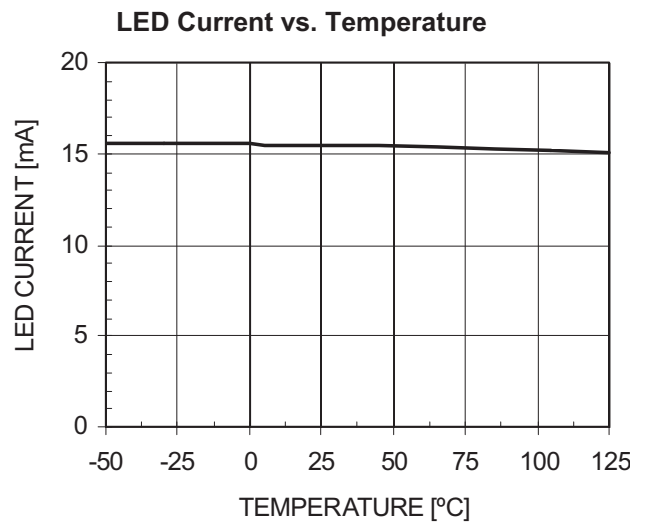
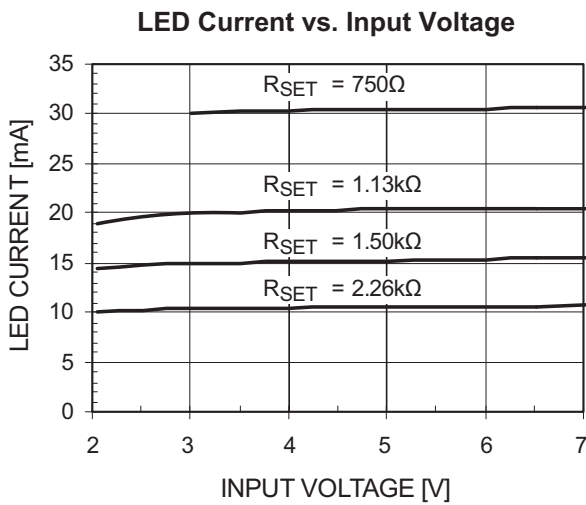
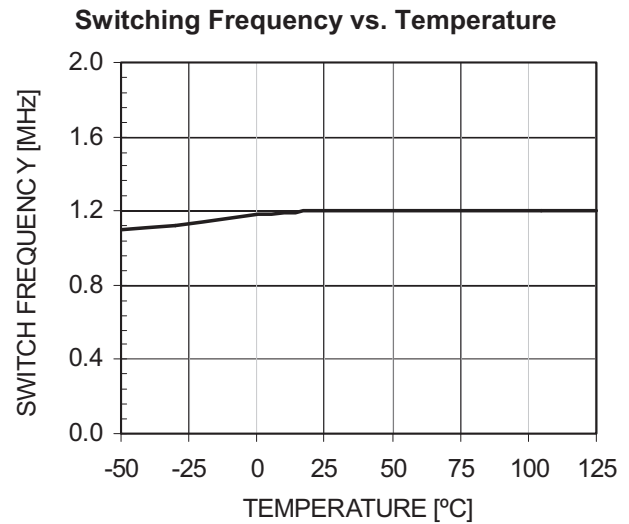
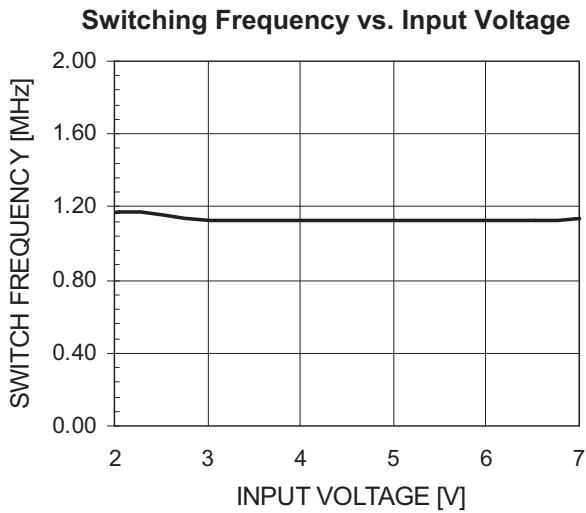
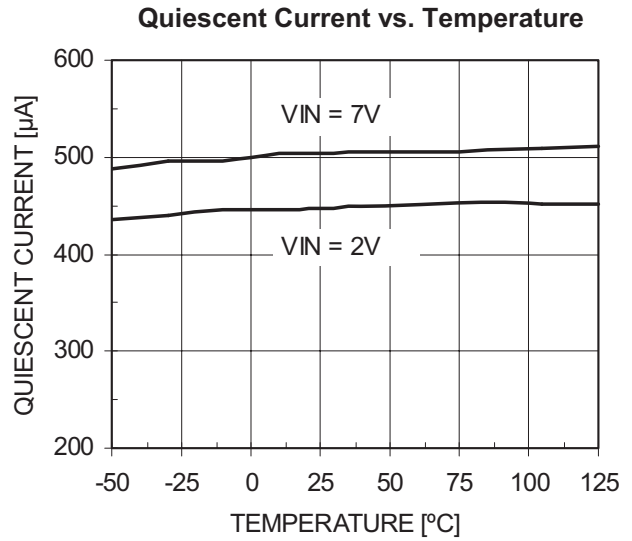
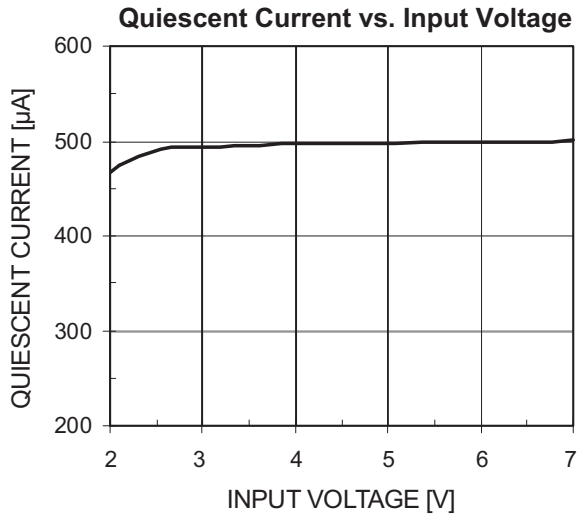

TYPICAL CHARACTERISTICS

$V_{IN} = 3.6V$, $T_{AMB} = 25^{\circ}C$, $C_{IN} = 4.7\mu F$, $C_{OUT} = 1\mu F$, $L = 6.8\mu H$, unless otherwise specified.

Switch Resistance vs. Input Voltage

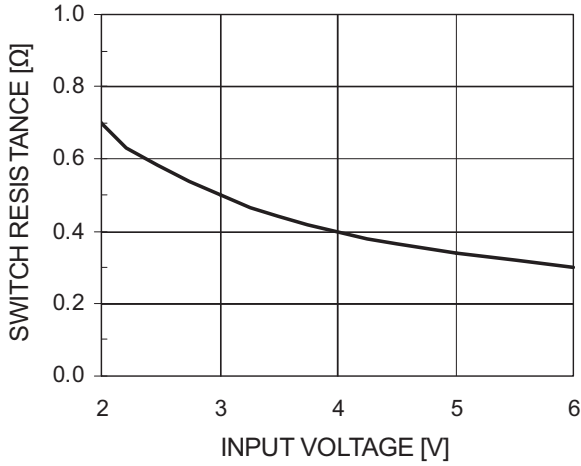

Switch Resistance vs. Temperature

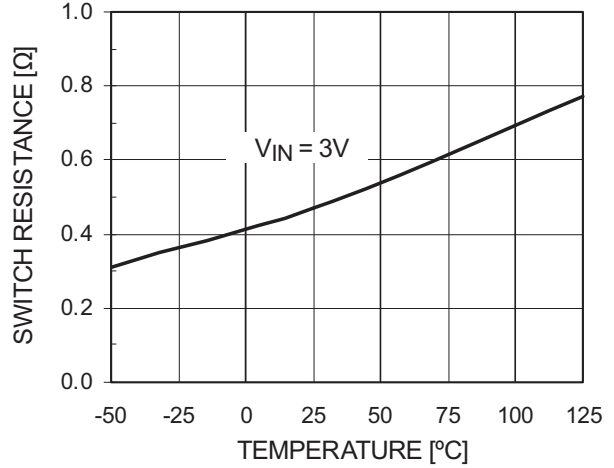

LED Pin Voltage vs. LED current

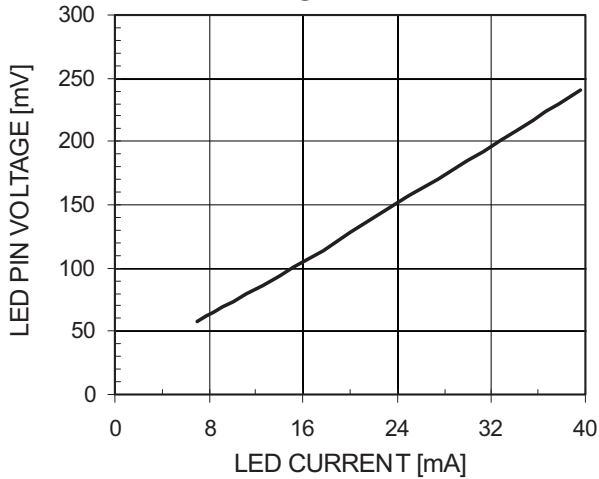

V_{SW} , I_L , & V_{OUT} Signal Waveforms

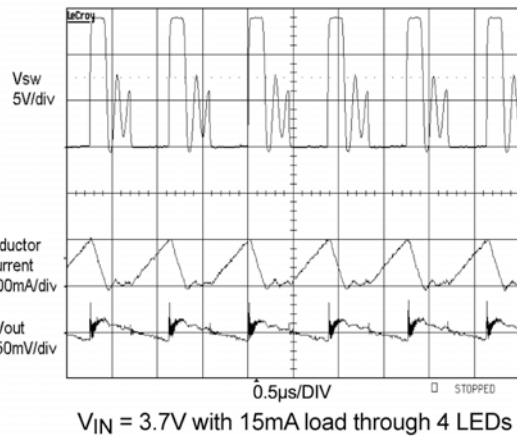

Efficiency vs. Input Voltage

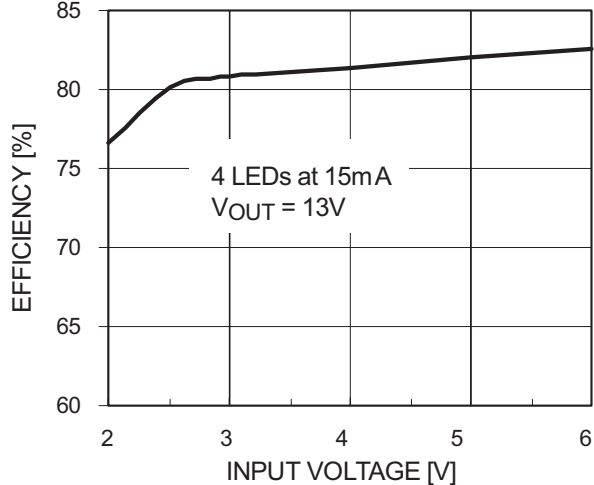

PWM on \overline{SHDN} pin Waveform

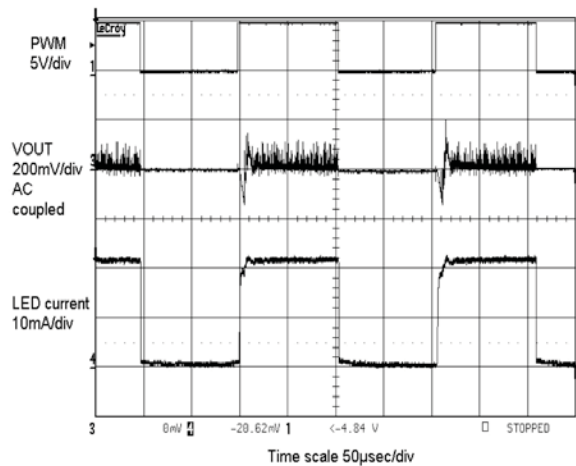

OPERATION

The W-52 device is a high efficiency, constant frequency, current regulating boost converter.

The device includes a switch and an internally compensated loop for the regulation of the LED current.

Operation can be best understood by examining the block diagram. The RSET pin is regulated at 100mV and the current through the external resistor will set the regulated current in the LEDs (from 5mA to 40mA) with a multiplication factor of 225.

While maintaining LED current regulation, the W-52 automatically adjusts the LED pin voltage to be as low

as possible. A low LED pin voltage ensures high efficiency.

Current through the internal power switch is continuously monitored cycle-by-cycle. If the current limit is exceeded, the switch is immediately turned off, protecting the device, for the remainder of the cycle.

PWM dimming operation can be achieved by switching the SHDN pin or by pulling the RSET pin higher than 0.1V.

BLOCK DIAGRAM

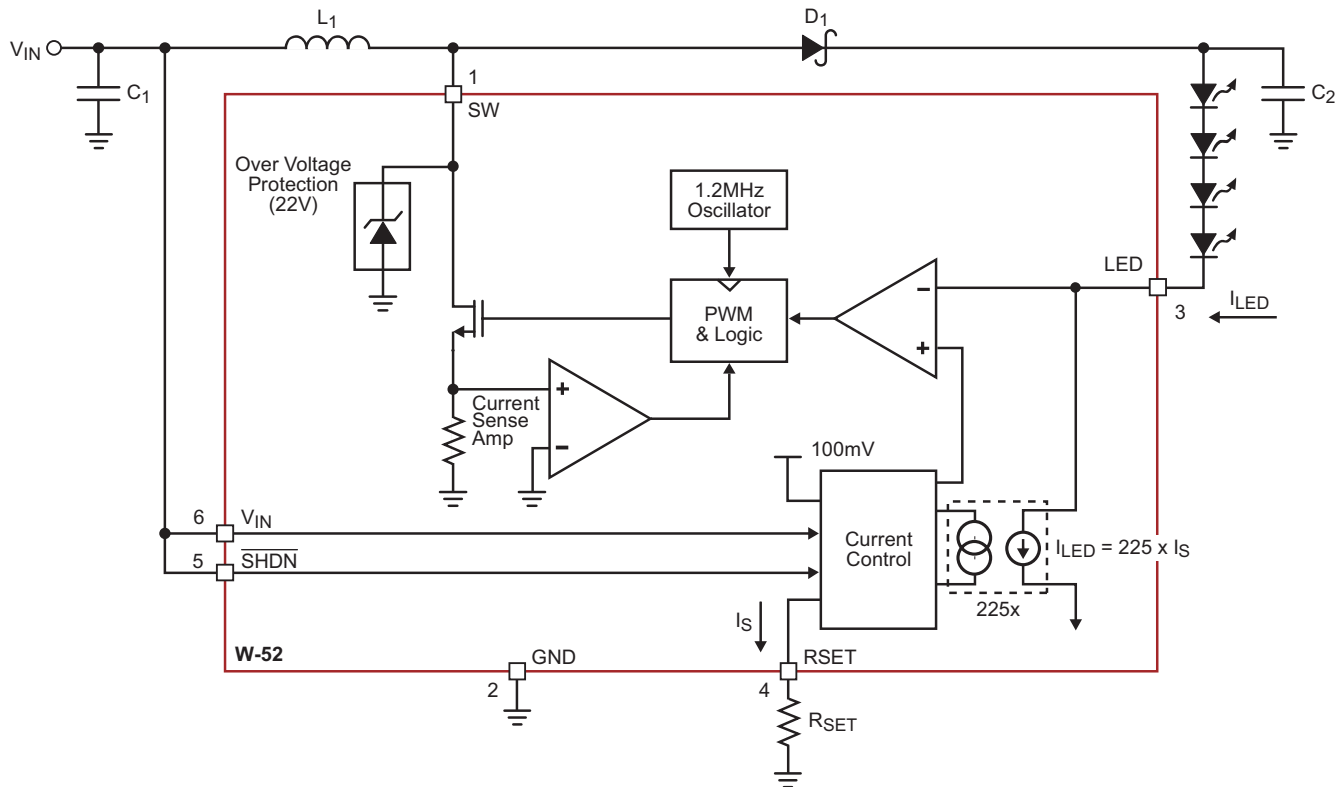

Figure 2. W-52 Block Diagram

APPLICATION INFORMATION

INDUCTOR SELECTION AND EFFICIENCY

Inductor vendors are shown below. Contact the manufacturer for detailed technical data and new product information.

Table 1: Inductor Manufacturers

Inductor	L (μH)	Maximum DCR (mΩ)	Maximum Height (mm)	Vendor	Web
ELJEA4R7	4.7	180	2.2	Panasonic 714.373.7334	www.panasonic.com
ELJEA6R8	6.8	250	2.2		
LQH3C4R7M24, LQH32CN4R7M11	4.7	260	2.2	Murata 770.436.1300	www.murata.com
LQH3C100K24, LQH32CN100K11	10	300	2.2		
LB2016B4R7	4.7	250	2.0	Taiyo Yuden 408.573.4150	www.t-yuden.com
LB2016B100	3.8	350	2.0		
CMD4D06-4R7	4.7	216	0.8	Sumida 847.956.0666	www.sumida.com
CMD4D06-6R8	6.8	296	0.8		
CLQ4D10-4R7	4.7	162	1.2		
CLQ4D10-6R8	6.8	195	1.2		

CAPACITOR SELECTION

Low ESR (equivalent series resistance) capacitors should be used at the output to minimize the output ripple voltage. The low ESR and small package options available with multilayer ceramic capacitors make them excellent choices. The X5R and X7R capacitor types are preferred because they retain their capacitance over wider voltage and temperature ranges than the Y5V or Z5U types. A 1.0μF or 2.2μF output capacitor is recommended for most applications.

The voltage rating of the output capacitor C2 depends on the number of LEDs driven in series. A 10V ceramic capacitor is recommended when driving two LEDs. A 16V ceramic capacitor is recommended when driving 3 or 4 LEDs.

Low profile ceramic capacitors with a 1mm maximum height/thickness are available for designs height requirements. Ceramic capacitors also make a good choice for the input capacitor, which should be mounted as close as possible to the W-52. A 2.2μF or 4.7μF input capacitor is recommended. Table 2 shows a list of several ceramic capacitor manufacturers. Consult the manufacturers for detailed information as new products and package options are introduced regularly.

Table 2: Ceramic Capacitor Manufacturers

Supplier	Phone	Web
Taiyo Yuden	408.573.4150	www.t-yuden.com
Murata	814.237.1431	www.murata.com
Kemet	408.986.0424	www.kemet.com

DIODE SELECTION

Schottky diodes, with their low forward voltage drop and fast switching speed, are the ideal choice for high efficiency applications. Table 3 shows several different Schottky diodes that work well with the W-52. Make sure that the diode has a voltage rating greater than the output voltage. The diode conducts current only when the power switch is turned off (typically less than one-third the time), so a 0.4A or 0.5A diode will be sufficient for most designs.

Table 3: Schottky Diode Suppliers

Part	Supplier
MBR0520	ON Semiconductor www.onsemi.com 800.282.9855
MBR0530 s	
MBR0540	
ZHCS400	Zetex

LED CURRENT PROGRAMMING

The LED current is programmed with a single resistor connected to the RSET pin. The RSET pin is internally regulated to 100mV, which sets the current flowing out of this pin, I_{RSET}, equal to 100mV/RSET. The W-52 regulates the current into the LED pin, I_{LED}, to 225 times the value of I_{RSET}. For the best accuracy, a 1% or better resistor is recommended. Table 4 shows several typical 1% R_{SET} values.

Table 4: R_{SET} Resistor Values

I _{LED} (mA)	R _{SET}
40	562Ω
30	750Ω
25	909Ω
20	1.13kΩ
15	1.50kΩ
10	2.26kΩ
5	4.53kΩ

For other LED current values, use the following equation to choose R_{SET}.

$$R_{SET} = 255 \times \frac{0.1V}{I_{LED}}$$

Most white LEDs are driven at maximum currents of 15mA to 20mA. Some higher power designs will use

two parallel strings of LEDs for greater light output, resulting in 30mA to 40mA (two strings of 15mA to 20mA) flowing into the LED pin.

LED DIMMING WITH PWM SIGNAL

PWM brightness control provides the widest dimming range (greater than 20:1). By turning the LEDs ON and OFF using the control signal the LEDs operate at either zero or full current, but their average current changes with the PWM signal duty cycle. Typically, a 5kHz to 40kHz PWM signal is used. PWM dimming with the W-52 can be accomplished two different ways.

The SHDN pin can be driven directly or a resistor can be added to drive the RSET pin. If the SHDN pin is used, increasing the duty cycle will increase the LED brightness. Using this method, the LEDs can be dimmed and turned off completely using the same control signal. A 0% duty cycle signal will turn off the W-52, reducing the total quiescent current to near zero.

$$R_{PWM} = R_{SET} \times \left(\frac{V_{MAX}}{0.15V} - 1 \right)$$

If the RSET pin is used, increasing the duty cycle will decrease the brightness. Using this method, the LEDs are dimmed using RSET and turned off completely using SHDN. If the RSET pin is used to provide PWM dimming, the approximate value of R_{PWM} should be calculated (where V_{MAX} is the "HIGH" value of the PWM signal):

In addition to providing the widest dimming range, PWM brightness control also ensures the "purest" white LED color over the entire dimming range. The true color of a white LED changes with operating current, and is the "purest" white at a specific forward current, usually 15mA or 20mA. If the LED current is less than or more than this value, the emitted light becomes more blue. Applications involving color LCDs can find the blue tint objectionable.

When a PWM control signal is used to drive the SHDN pin of the W-52, the LEDs are turned off and on at the PWM frequency. The current through them alternates between full current and zero current, so the average current changes with duty cycle. This ensures that when the LEDs are on, they can be driven at the appropriate current to give the purest white light. LED brightness varies linearly with the PWM duty cycle.

LED DIMMING WITH A LOGIC SIGNAL

For applications that need to adjust the LED brightness in discrete steps, a logic signal can be used. R_{MIN} sets the minimum LED current value (when the NMOS is OFF):

$$R_{MIN} = 255 \times \frac{0.1V}{I_{LED(MIN)}}$$

R_{INCR} determines how much LED current increases when the external NMOS switch is turned ON.

$$R_{INCR} = 255 \times \frac{0.1V}{I_{LED(Increase)}}$$

LED DIMMING WITH A DC VOLTAGE

$$R_{ADJ} = 225 \times \frac{V_{MAX} - 0.1V}{I_{LED(MAX)} - I_{LED(MIN)}}$$

PCB Layout Guidelines

The W-52 is a high-frequency switching regulator and therefore proper PCB board layout and component placement can minimize noise and radiation and increase efficiency. To maximize efficiency, the W-52 design has fast switch rise and fall times. To prevent radiation and high frequency resonance problems minimize the length and area of all traces connected to the SW pin and use a ground plane under the switching regulator.

The switch, schottky output diode and output capacitor signal path should be kept as short as possible. The ground connection for the R_{SET} resistor should be tied directly to the GND pin and not be shared with other components.

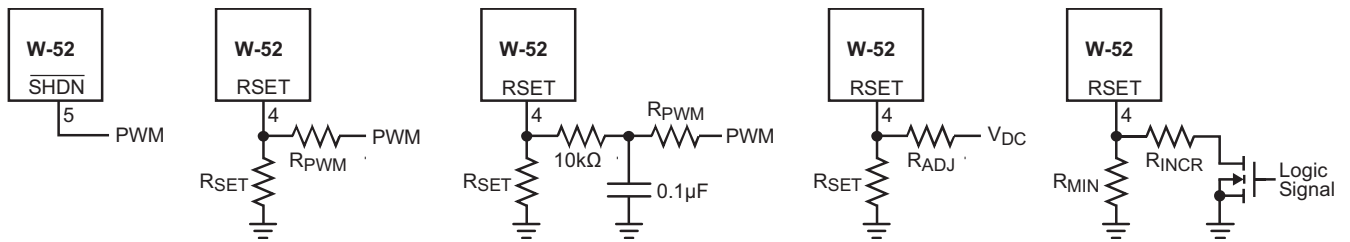
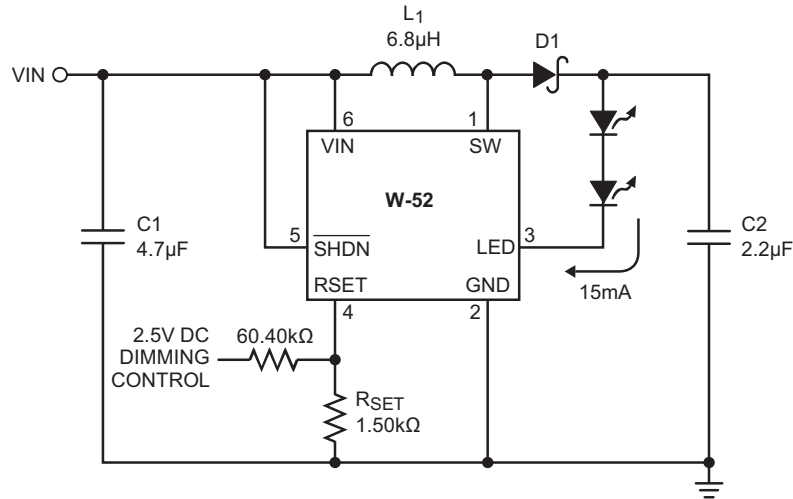

Figure 3. LED Dimming Circuits

TYPICAL APPLICATION CIRCUITS

The application diagrams below are shown for the TSOT-23 packages.

Two LEDs with DC Level Dimming Control



Three LEDs with DC Level Dimming Control

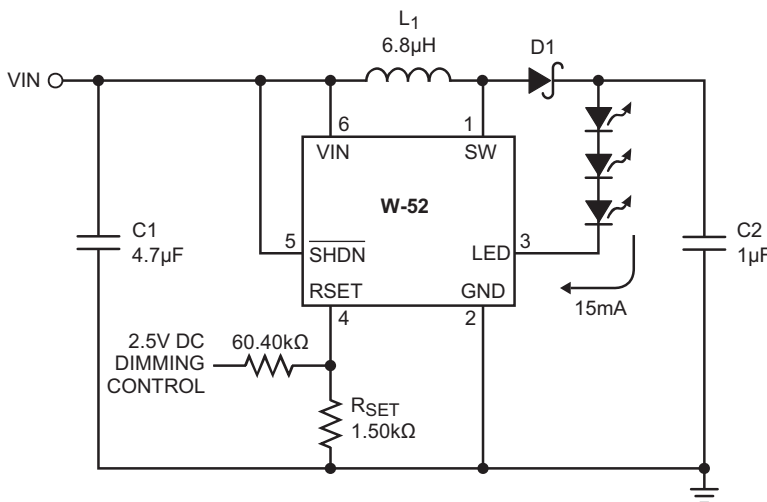

Efficiency - Three LEDs

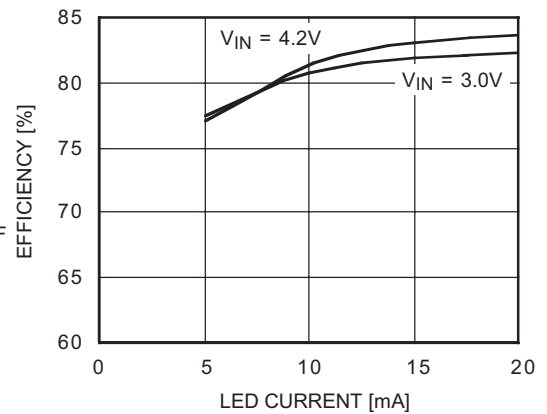

Four LEDs with PWM Dimming Control

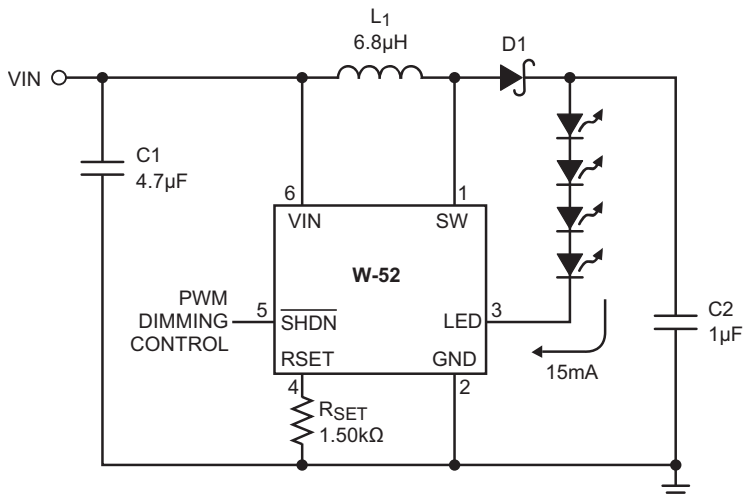

Efficiency - Four LEDs

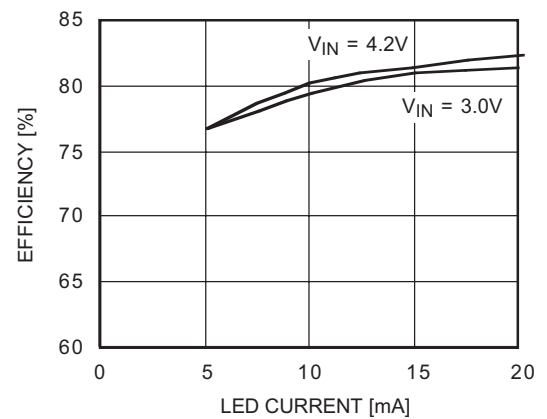

PACKAGE OUTLINE DRAWINGS

TSOT-23 6-Lead (TD) ⁽¹⁾⁽²⁾

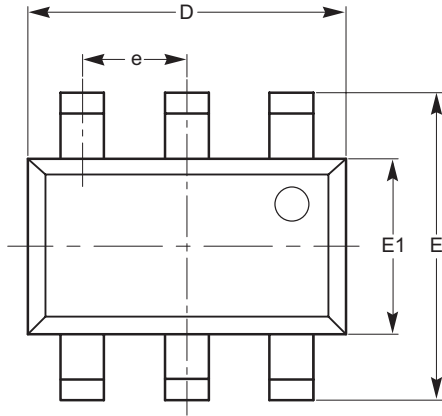

TOP VIEW

SYMBOL	MIN	NOM	MAX
A			1.00
A1	0.01	0.05	0.10
A2	0.80	0.87	0.90
b	0.30		0.45
c	0.12	0.15	0.20
D	2.90 BSC		
E	2.80 BSC		
E1	1.60 BSC		
e	0.95 TYP		
L	0.30	0.40	0.50
L1	0.60 REF		
L2	0.25 BSC		
θ	0°		8°

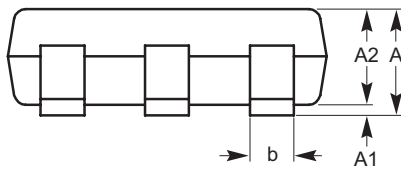

SIDE VIEW

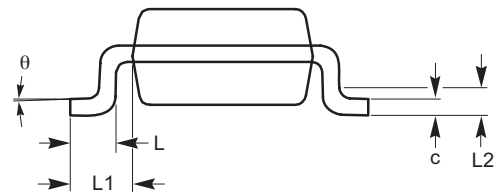

END VIEW

Notes:

- (1) All dimensions are in millimeters. Angles in degrees.
- (2) Complies with JEDEC standard MO-193.

EXAMPLE OF ORDERING INFORMATION

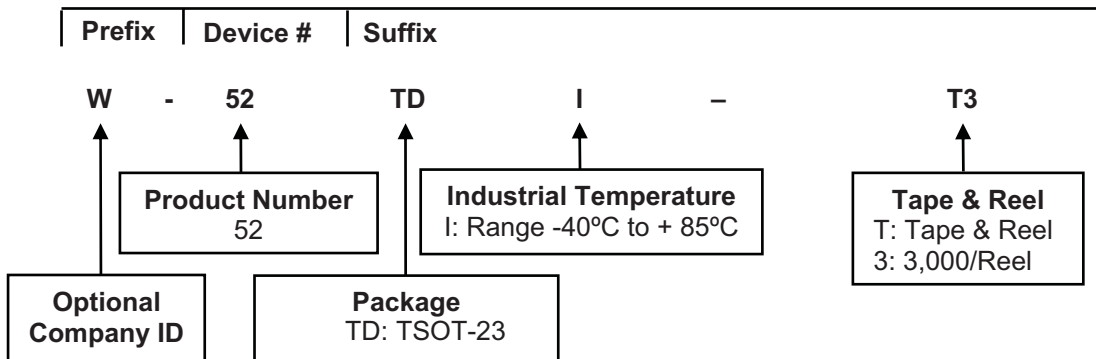

Notes:

- (1) All packages are RoHS-compliant (Lead-free, Halogen-free).
- (2) The device used in the above example is a W-52TDI-T3 (TSOT-23, Tape & Reel, 3,000/Reel).
- (3) For additional package and temperature options, please contact your nearest COPAL ELECTRONICS Sales office.

REVISION HISTORY

Date	Rev.	Reason
9-Oct-03	AA	Revised Typical Characteristics plots
11-Feb-04	AB	Revised Efficiency plots
1-Nov-04	AC	Added Green package designation Eliminated TDFN (3 x 4.9mm) package
28-Sept-07	AC-01	Update Ordering Information
23-May-08	AD	Update Package Outline Drawings Delete PbSn plated finish Add Example of Ordering Information Add MD- to document number.

NIDEC COPAL ELECTRONICS CORP. MAKES NO WARRANTY, REPRESENTATION OR GUARANTEE, EXPRESS OR IMPLIED, REGARDING THE SUITABILITY OF ITS PRODUCTS FOR ANY PARTICULAR PURPOSE, NOR THAT THE USE OF ITS PRODUCTS WILL NOT INFRINGE ITS INTELLECTUAL PROPERTY RIGHTS OR THE RIGHTS OF THIRD PARTIES WITH RESPECT TO ANY PARTICULAR USE OR APPLICATION AND SPECIFICALLY DISCLAIMS ANY AND ALL LIABILITY ARISING OUT OF ANY SUCH USE OR APPLICATION, INCLUDING BUT NOT LIMITED TO, CONSEQUENTIAL OR INCIDENTAL DAMAGES.

NIDEC COPAL ELECTRONICS CORP. products are not designed, intended, or authorized for use as components in systems intended for surgical implant into the body, or other applications intended to support or sustain life, or for any other application in which the failure of the NIDEC COPAL ELECTRONICS CORP. product could create a situation where personal injury or death may occur.

NIDEC COPAL ELECTRONICS CORP. reserves the right to make changes to or discontinue any product or service described herein without notice. Products with data sheets labeled "Advance Information" or "Preliminary" and other products described herein may not be in production or offered for sale.

NIDEC COPAL ELECTRONICS CORP. advises customers to obtain the current version of the relevant product information before placing orders. Circuit diagrams illustrate typical semiconductor applications and may not be complete.

COPAL ELECTRONICS

NIDEC COPAL ELECTRONICS CORP.
Japan Head Office
Nishi-Shinjuku, Kimuraya Bldg.,
7-5-25 Nishi-Shinjuku, Shinjuku-ku, Tokyo 160-0023
Phone: +81-3-3364-7055
Fax: +81-3-3364-7098
www.nidec-copal-electronics.com

Document No: MD-5001
Revision: AD
Issue date: 05/23/2008