

CMOS White LED Driver Boost Converter

**HALOGEN FREE
LEAD FREE**

FEATURES

- Low quiescent ground current (0.5mA typical)
- Power efficiency over 80%
- Compatible pinout with LT1937
- Adjustable output current (up to 40mA)
- High frequency 1.2MHz operation
- Input voltage operation down to 2.5V
- Low resistance (0.5Ω) power switch
- Drives up to 4 White LEDs in series
- Shutdown current less than 1μA
- Load fault protection against open-circuits
- Low value external components
- Low profile (1mm) TSOT-23 5-lead package

APPLICATION

- Color LCD and keypad backlighting
- Cellular phones
- Handheld terminals
- Digital cameras
- PDAs/Games
- Portable MP3 players

For Ordering Information details, see page 11.

DESCRIPTION

The W-57 is a DC/DC step up converter that delivers a regulated output current. Operation at a constant switching frequency of 1.2MHz allows the device to be used with very small value external inductor and ceramic capacitors.

The W-57 is targeted to drive multiple white light-emitting diodes (LEDs) connected in series and provides the necessary regulated current to control the brightness and the color purity. An external resistor R1 controls the output current level. LED currents of up to 40mA can be supported over a wide range of input supply voltages from 2.5V to 7V, making the device ideal for battery-powered applications.

A high voltage output stage allows up to 4 White LEDs to be driven in series. Series drive provides inherent current matching.

LED dimming can be done by using a DC voltage, a logic signal, or a pulse width modulation (PWM) signal. The shutdown input pin allows the device to be placed in power-down mode with “near zero” quiescent current.

In addition to overcurrent limiting protection, the device also includes detection circuitry to ensure protection against open-circuit load fault conditions.

The device is available in a low profile (1mm max height) 5-lead TSOT-23 package.

TYPICAL APPLICATION CIRCUIT

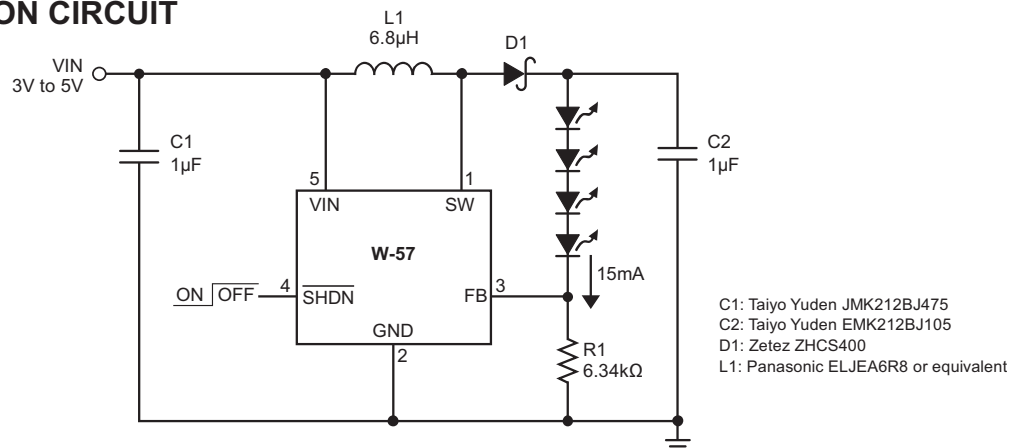
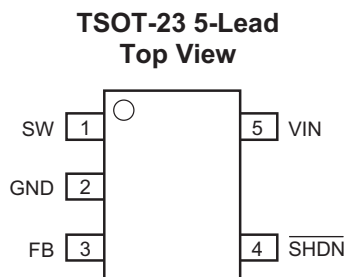

Figure 1. Driver for Four High-Brightness White LEDs

ORDERING INFORMATION

Part Number	Package	Quantity per Reel	Package Marking
W-57TDI-T3	TSOT-23 5-lead	3,000	LM

PIN CONFIGURATION



1mm maximum height
 $\theta_{JA} = 250^{\circ}\text{C/W}$ [free air]

PIN DESCRIPTION

Pin Number	Name	Function
1	SW	Switch pin. This is the drain of the internal power switch. For minimum EMI, minimize the trace area connected to this pin.
2	GND	Ground pin. Connect pin 2 to ground.
3	FB	LED (cathode) connection pin.
4	$\overline{\text{SHDN}}$	Shutdown pin.
5	VIN	Input supply pin. This pin should be bypassed with a capacitor to ground. A $1\mu\text{F}$ capacitor mounted close to the pin is recommended.

ABSOLUTE MAXIMUM RATINGS ⁽¹⁾

Parameter	Rating	Unit
V _{IN} , FB, SHDN voltage	8	V
SW voltage	20	V
Storage Temperature Range	-65 to +160	°C
Junction Temperature	125	°C
Lead Soldering Temperature (10 secs)	300	°C
ESD Rating – Human Body Model	2000	V

RECOMMENDED OPERATING CONDITIONS

Parameter	Range	Unit
V _{IN}	2.5 to 7	V
Ambient Temperature Range	-40 to +85	°C
Inductor L1	6.8 ± 20% typical	μH
Input Capacitor C1	1.0 ± 20% typical	μF
Output Capacitor C2	1.0 ± 20% typical	μF
I _{LED} with 1 to 4 LEDs in series	0 to 20	mA

Typical application circuit with external components is shown on page 1.

ELECTRICAL OPERATING CHARACTERISTICS

Over recommended operating conditions unless otherwise specified. T_A = 25°C, V_{IN} = 3V and V_{SHDN} = 3V.

Symbol	Parameter	Conditions	Min	Typ	Max	Units
	Input Voltage Range		2.5		7	V
I _Q	Quiescent Current	V _{FB} = 0.2 V		0.5	0.7	mA
I _{SD}	Shutdown Current	V _{SHDN} = 0 V		0.05	1	μA
V _{FB}	FB Pin Voltage	4 LEDs at 15 mA	85	95	105	mV
I _{FB}	FB Pin Leakage Current			1	2	μA
	Shutdown High Threshold		0.85			V
	Shutdown Low Threshold				0.25	V
I _{SHDN}	Shutdown Pin Current				1	nA
f _{SW}	Boost Converter Frequency		0.8	1.2	1.6	MHz
DC	Maximum Switch Duty Cycle		90	95		%
I _{SWL}	Switch Current Limit		400	550	780	mA
	Switch Saturation Voltage	I _{SW} = 300 mA		150	200	mV
	Switch Leakage Current	Switch Off, V _{SW} = 5 V		0.01	5	μA
	Efficiency	Figure 1 with specified components		83		%

Notes:

- (1) These are stress ratings only and functional operation is not implied. Exposure to absolute maximum ratings for prolonged time periods may affect device reliability. All voltages are with respect to ground.

TYPICAL CHARACTERISTICS

$V_{IN} = 3.6V$, $T_{AMB} = 25^{\circ}C$, $C_{IN} = 4.7\mu F$, $C_{OUT} = 1\mu F$, $L = 6.8\mu H$, unless otherwise specified.

LED Current vs. Input Voltage

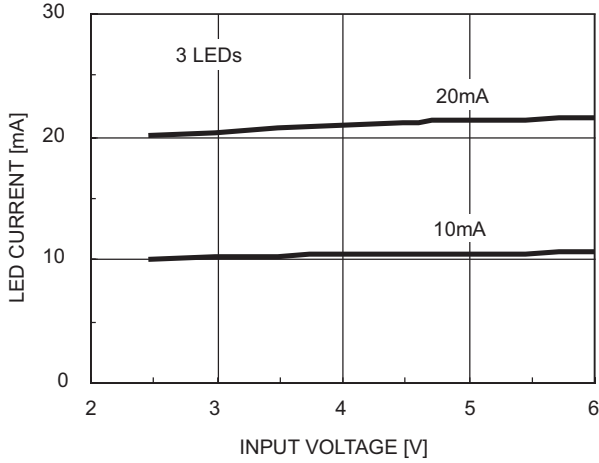

LED Current vs. Temperature

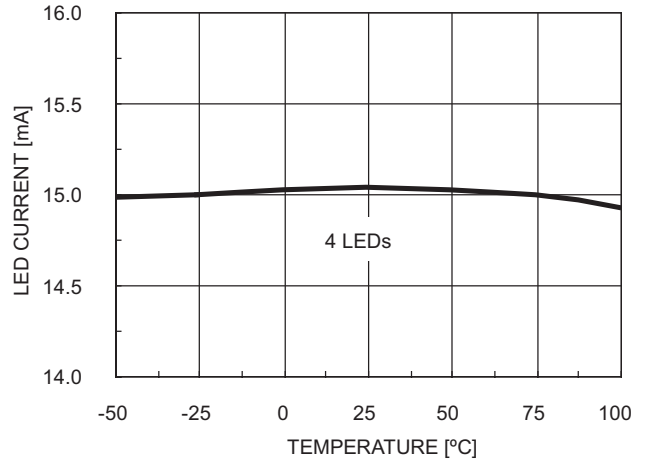

FB Pin Voltage vs. LED Current

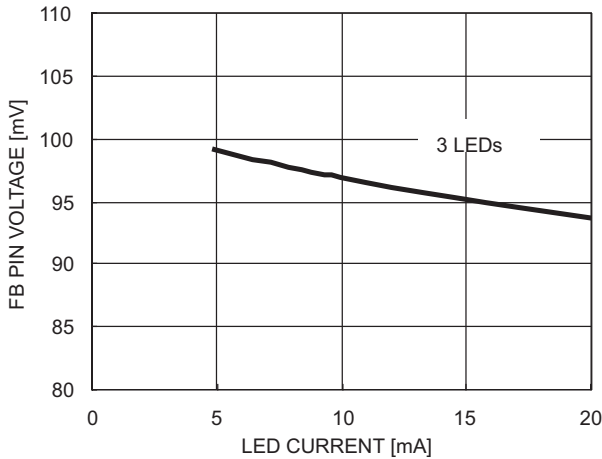

FB Pin Voltage vs. Temperature

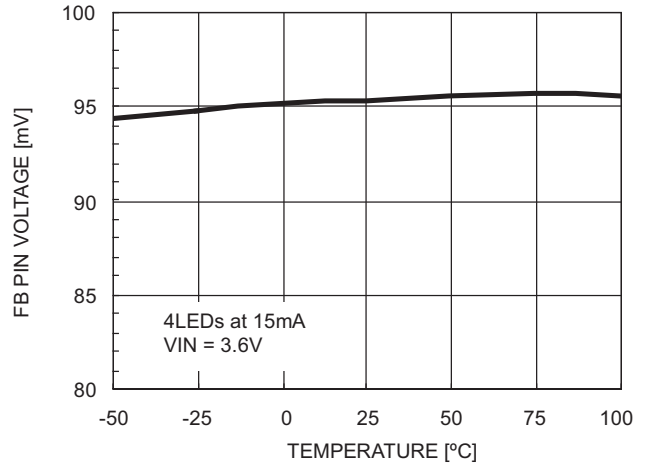

Switching Frequency vs. Input Voltage

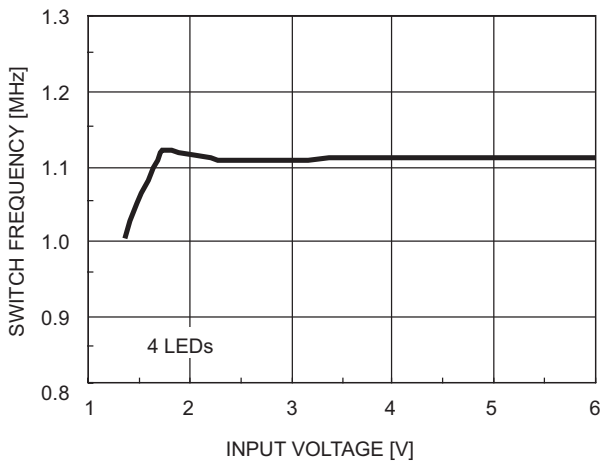

Switching Frequency vs. Temperature

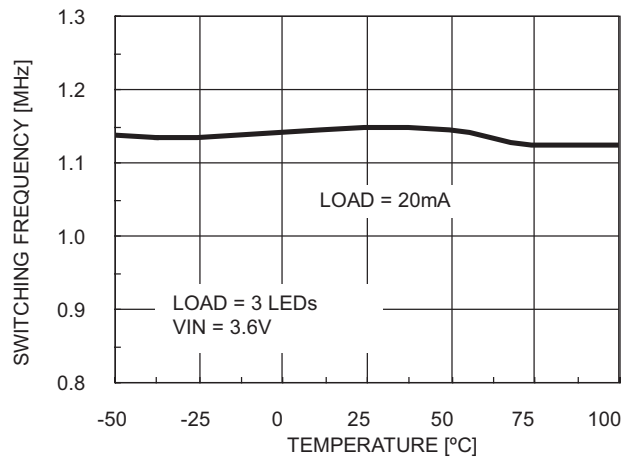

TYPICAL CHARACTERISTICS

$V_{IN} = 3.6V$, $T_{AMB} = 25^{\circ}C$, $C_{IN} = 4.7\mu F$, $C_{OUT} = 1\mu F$, $L = 6.8\mu H$, unless otherwise specified.

Efficiency vs. Input Voltage

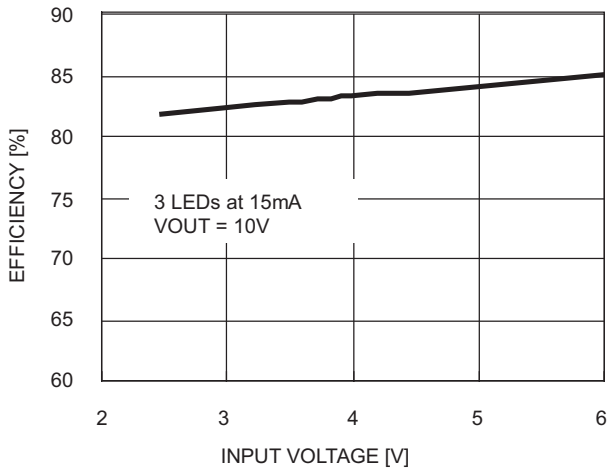

Efficiency vs. Temperature

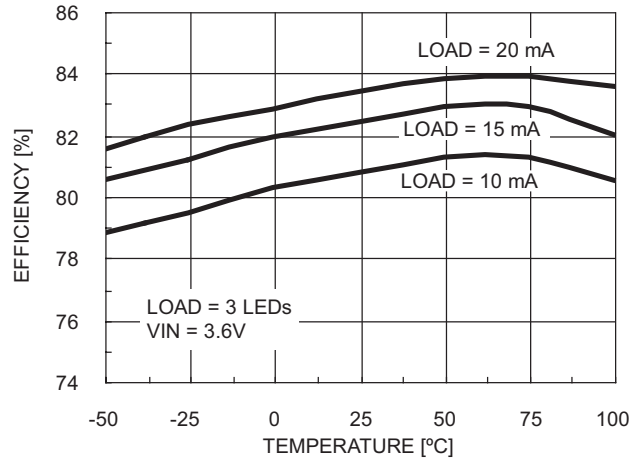

V_{sw}, I_L, & V_{OUT} Waveforms

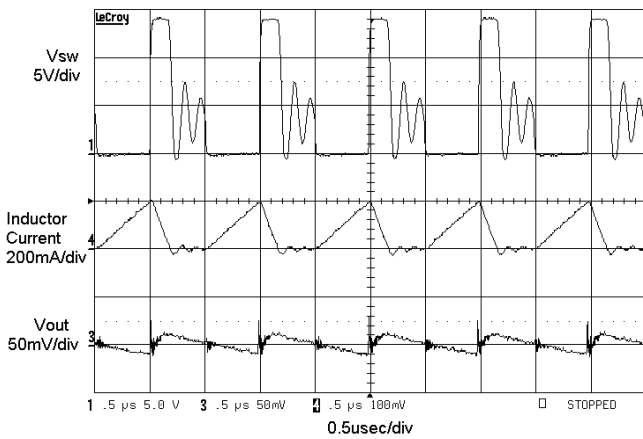

PWM on SHDN pin at 1kHz

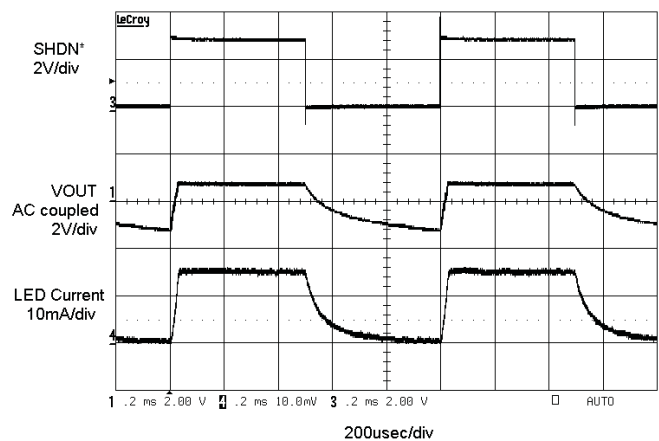

Enable Power-Up Waveforms

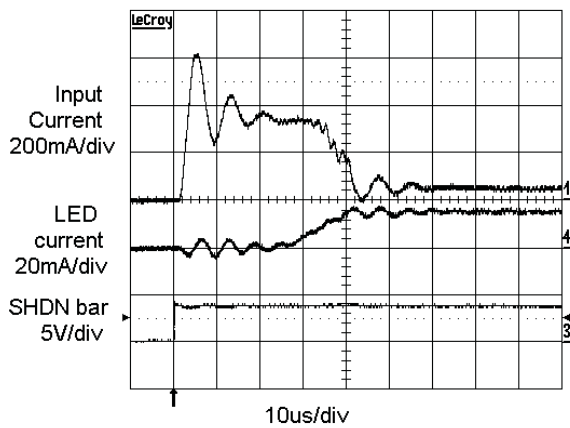

OPERATION

The W-57 device is a high efficiency, constant frequency, current regulating boost driver for white LEDs.

The device includes a switch and an internally compensated loop for the regulation of the current in the LEDs.

Operation can be best understood by examining the block diagram. The FB pin is regulated at 95mV and the current through the external resistor will set the regulated current in the LEDs at:

$$I_{LED} = \frac{0.095}{R1}$$

While maintaining LED current regulation, the W-57 boost converter automatically adjusts the FB pin voltage to be as low as possible. A low FB pin voltage ensures high efficiency.

Current through the internal power switch is continuously monitored cycle-by-cycle. If the current limit is exceeded, the switch is immediately turned off, protecting the device, for the remainder of the cycle.

PWM dimming operation can be achieved by switching the SHDN pin or by pulling the FB pin higher than 95mV.

BLOCK DIAGRAM

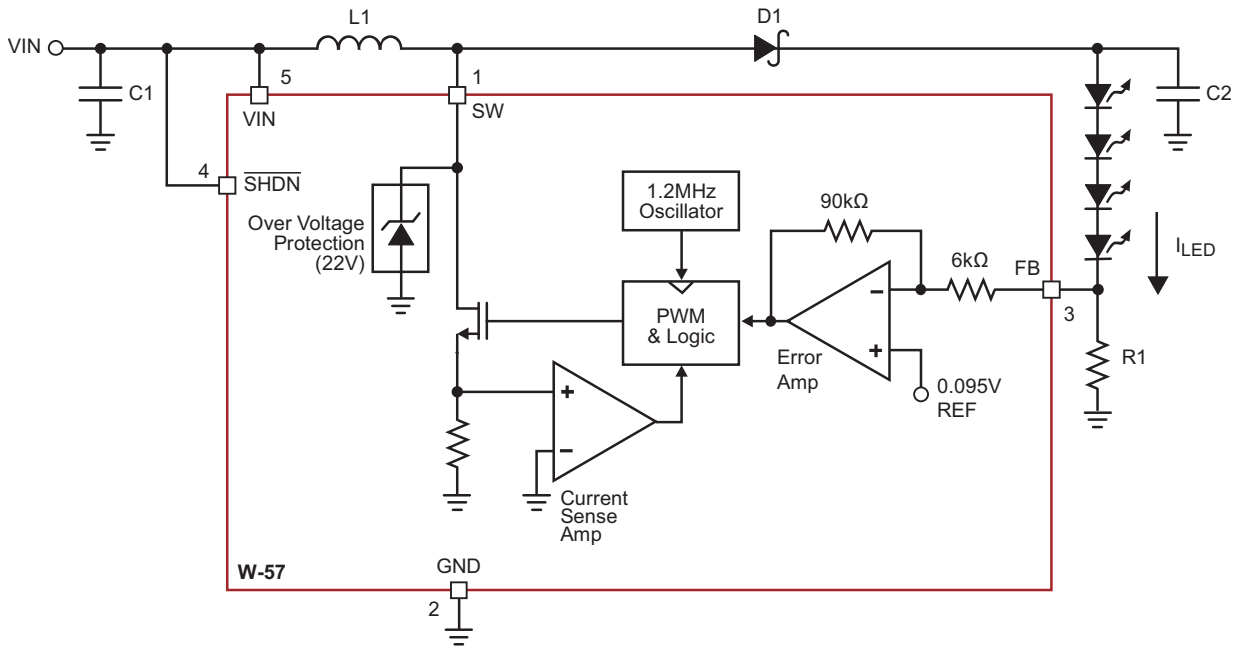

Figure 2. W-57 Block Diagram

APPLICATION INFORMATION

CAPACITOR SELECTION

Low ESR (equivalent series resistance) capacitors should be used at the output to minimize the output ripple voltage. The low ESR and small package options available with multilayer ceramic capacitors make them excellent choices. The X5R and X7R capacitor types are preferred because they retain their capacitance over wider voltage and temperature ranges than the Y5V or Z5U types. A 1.0µF output capacitor is recommended for most applications.

The voltage rating of the output capacitor C2 depends on the number of LEDs driven in the series. A 16V ceramic capacitor is recommended when driving 3 or 4 LEDs.

Low profile ceramic capacitors with a 1mm maximum height/thickness are available for designs height requirements. Ceramic capacitors also make a good choice for the input capacitor, which should be mounted as close as possible to the W-57. A 1µF or 4.7µF input capacitor is recommended. Table 1 shows a list of several ceramic capacitor manufacturers. Consult the manufacturers for detailed information as new products and package options are introduced regularly.

Table 1: Ceramic Capacitor Manufacturers

Supplier	Web
Taiyo Yuden	www.t-yuden.com
Murata	www.murata.com
Kemet	www.kemet.com
AVX	www.avxcorp.com

DIODE SELECTION

Schottky diodes, with their low forward voltage drop and fast switching speed, are the ideal choice for high efficiency applications. Table 2 shows several different Schottky diodes that work well with the W-57. Make sure that the diode has a voltage rating greater than the output voltage. The diode conducts current only when the power switch is turned off (typically less than one-third the time), so a 0.4A or 0.5A diode will be sufficient for most designs.

Table 2: Schottky Diode Suppliers

Part	Supplier
MBR0520	ON Semiconductor www.onsemi.com 800.282.9855
MBR0530	
MBR0540	
ZHCS400	Zetex

LED CURRENT PROGRAMMING

The LED current is programmed with a single resistor connected to the FB pin. The FB pin is internally regulated to 95 mV, which sets the current flowing through R1 and the LEDs as equal to 0.095/R1. For the best accuracy, a 1% or better resistor is recommended. Table 3 shows several typical 1% R1 values.

Table 4: R₁ Resistor Values

I _{LED} (mA)	R ₁ (Ω)
40	2.37
30	3.16
25	4.75
20	6.34
15	7.87
10	9.53
5	19.1

For other LED current values, use the following equation to choose R1.

$$R1 = \frac{0.095}{I_{LED}}$$

Most white LEDs are driven at maximum currents of 15mA to 20mA. Some higher power designs will use two parallel strings of LEDs for greater light output, resulting in 30mA to 40mA (two strings of 15mA to 20mA) flowing through the R1 resistor.

LED DIMMING WITH DC SIGNAL

Dimming the LEDs can be done by applying a variable DC voltage as shown on Figure 3. As the V_{DC} increase the voltage across R1 decreases and therefore lower the LED current. The resistors R2 and R3 must be large enough so that their current (tens of μA) is much smaller than the LED current but much larger than the FB leakage current (I_{FB}). When adjusting V_{DC} between 0V and 2V, the resistors shown on Figure 3 will set the LED current between 0mA and 15mA.

LED DIMMING WITH PWM SIGNAL

PWM brightness control provides the widest dimming range (greater than 20:1). By turning the LEDs ON and OFF using the control signal, the LEDs operate at either zero or full current, but their average current changes with the PWM signal duty cycle. Typically, a 5kHz to 40kHz PWM signal is used.

A filtered PWM signal is used to dim the LEDs, as shown in Figure 4.

In addition to providing the widest dimming range, PWM brightness control also ensures the “purest” white LED color over the entire dimming range. The true color of a white LED changes with operating current, and is the “purest” white at a specific forward current, usually 15mA or 20mA. If the LED current is less than or more than this value, the emitted light becomes more blue. Applications involving color LCDs can find the blue tint objectionable.

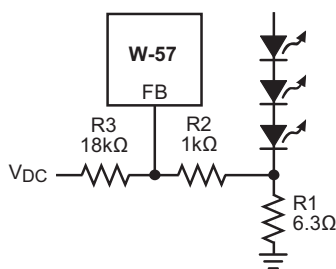

Figure 3. Dimming with a DC Voltage

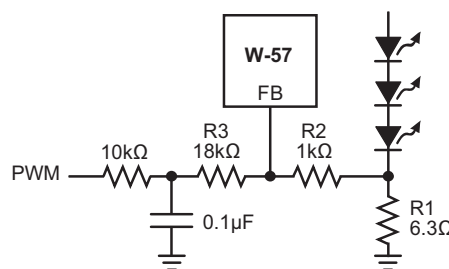

Figure 4. Dimming with a Filtered PWM Signal

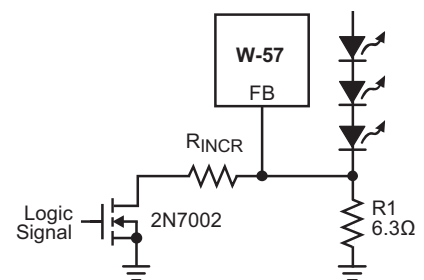

Figure 5. Dimming with a Logic Signal

LED DIMMING WITH A LOGIC SIGNAL

For applications that need to adjust the LED brightness in discrete steps, a logic signal can be used as shown in Figure 5. R1 sets the minimum LED current value (when the NMOS switch is OFF):

$$R1 = \frac{0.095V}{I_{LED(MIN)}}$$

R_{INCR} determines how much LED current increases when the external NMOS switch is turned ON.

$$R_{INCR} = \frac{0.095V}{I_{LED(INCREASE)}}$$

PCB LAYOUT GUIDELINES

The W-57 is a high-frequency switching regulator where proper PCB board layout and component placement can minimize noise and radiation and increase efficiency. To maximize efficiency, the W-57 design has fast switch rise and fall times. To prevent radiation and high frequency resonance problems minimize the length and area of all traces connected to the SW pin and use a ground plane under the switching regulator.

The SW pin, schottky diode and capacitor C2 signal path should be kept as short as possible. The ground connection for the R1 resistor should be tied directly to the GND pin and not be shared with other components.

TYPICAL APPLICATION CIRCUITS

Two LEDs with DC Level Dimming Control

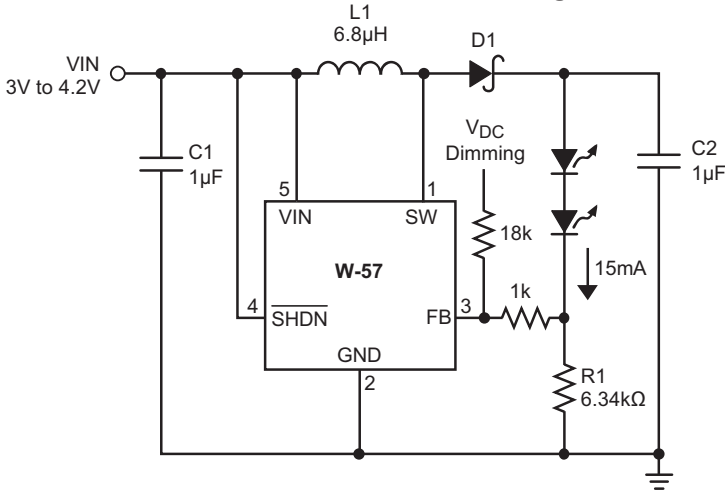

Efficiency – Two LEDs

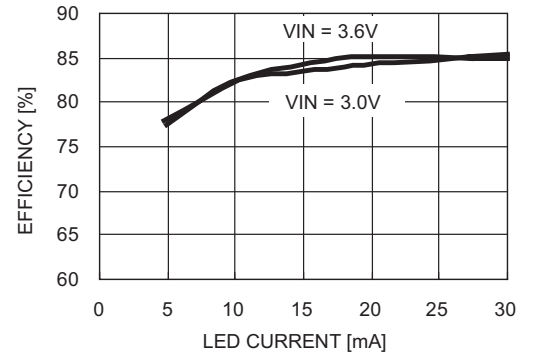

Three LEDs with DC Level Dimming Control

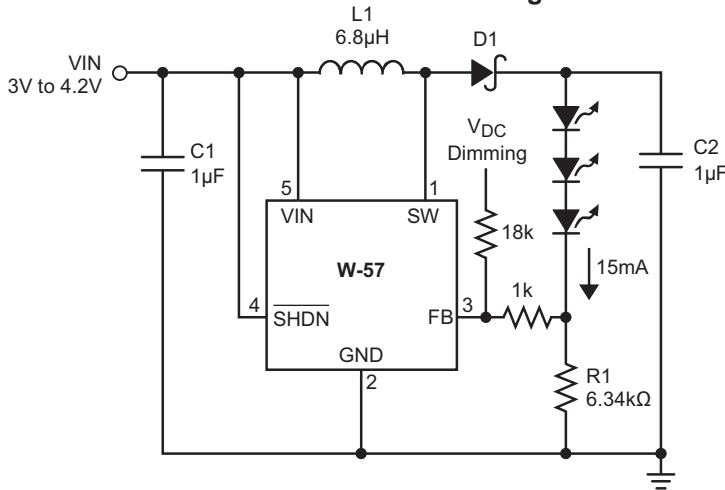

Efficiency -- Three LEDs

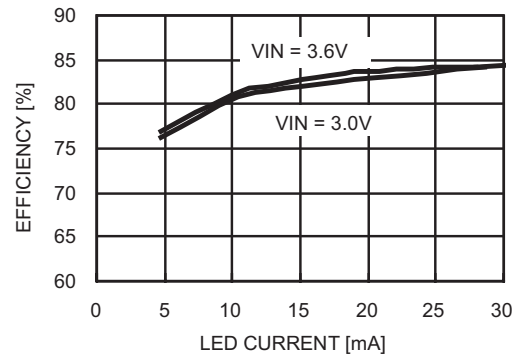

Four LEDs with PWM Dimming Control

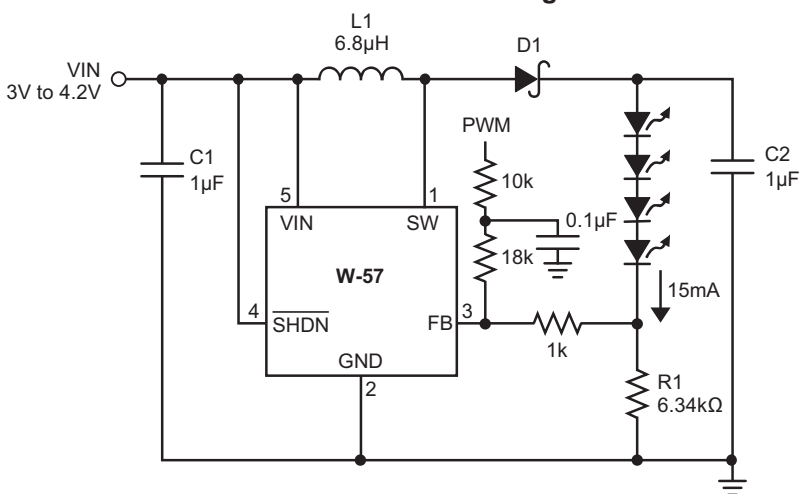

Efficiency – Four LEDs

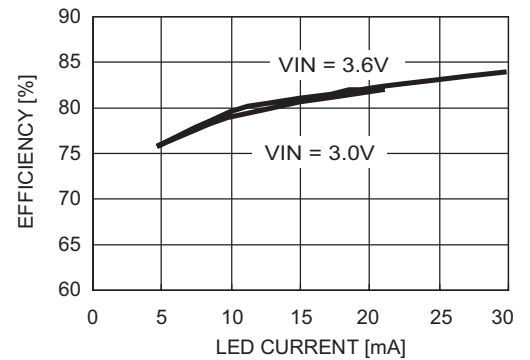

PACKAGE OUTLINE DRAWING

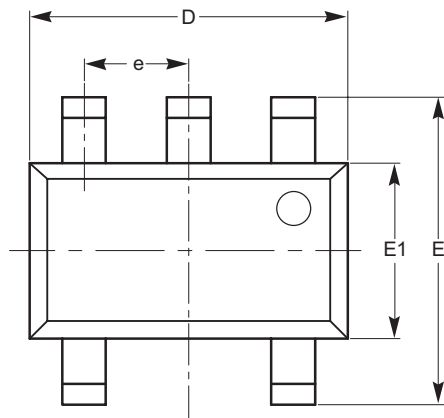
TSOT-23 5-Lead (TD)⁽¹⁾⁽²⁾

TOP VIEW

SYMBOL	MIN	NOM	MAX
A			1.00
A1	0.01	0.05	0.10
A2	0.80	0.87	0.90
b	0.30		0.45
c	0.12	0.15	0.20
D	2.90 BSC		
E	2.80 BSC		
E1	1.60 BSC		
e	0.95 TYP		
L	0.30	0.40	0.50
L1	0.60 REF		
L2	0.25 BSC		
θ	0°		8°

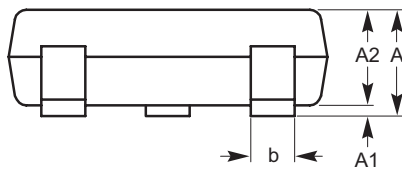

SIDE VIEW

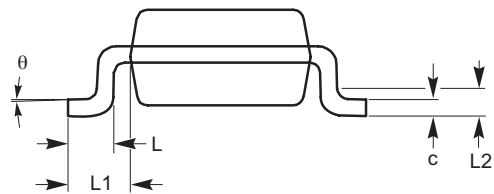

END VIEW

Notes:

- (1) All dimensions are in millimeters. Angles in degrees.
- (2) Complies with JEDEC standard MO-193.

EXAMPLE OF ORDERING INFORMATION

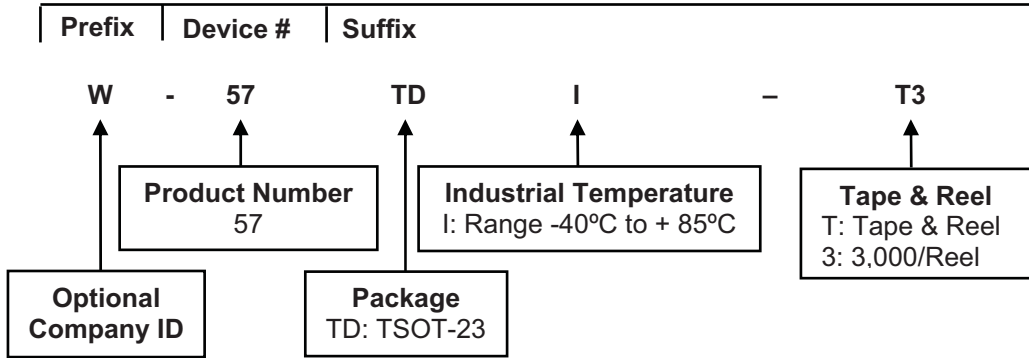

Notes:

- (1) All packages are RoHS-compliant (Lead-free, Halogen-free).
- (2) The device used in the above example is a W-57TDI-T3 (TSOT-23, Tape & Reel, 3,000/Reel).
- (3) For additional package and temperature options, please contact your nearest COPAL ELECTRONICS Sales office.

REVISION HISTORY

Date	Rev.	Reason
25-Sept-03	H	Updated Ordering Information - part numbers Changed L1 for each figure from 22 μ H to 6.8 μ H Changed VIN for Typical Application from 2.7V to 4.2V to 3V to 5V Changed C1 for each typical application circuit from 4.7 μ F to 1 μ F Changed C2 for each typical application circuit from 2.2 μ F to 1 μ F Changed VIN for each for each typical application circuit from 1.8V to 3V to 3V to 4.2V
25-Sept-03	I	Updated Ordering Information - part numbers
6-Nov-03	J	Updated Features Changed R1 for Typical Application figure and Typical Application Circuit figures from 6.34 Ω to 6.8 Ω Updated Description (2V to 2.5V input supply voltage) Updated Ordering Information (added package marking code) Updated Electrical Specifications Updated Table 4 (R1 Resistor Value) with new values Updated LED dimming with logic signal (0.095V to 0.105V)
8-Dec-03	K	Updated Typical Application figures Updated Electrical Specifications Updated Operation text Updated LED current programming text Updated Table 4 (R1 Resistor Value) with new values Updated LED dimming equations Updated Typical Application Circuit figures
10-Dec-03	L	Updated FB Pin Leakage Current in Electrical Specifications
18-Dec-03	M	Added Typical Characteristics graphs (pages 4-6) Added Efficiency graphs to Typical Application Circuits Changed package drawing for 5-lead SOT-23
22-Dec-03	N	Updated Absolute Maximum Ratings Deleted temp range from Electrical Specifications Added Recommended Operating Conditions Updated Block Diagram
9-June-04	O	Updated Electrical Specifications (changed V_{RSET} to V_{FB} in I_Q)
15-June-04	P	Reoved Preliminary data sheet designation
22-Sept-04	Q	Added Green Packages in all areas
1-Nov-04	R	Eliminated TDFN (3 x 4.9mm) package Updated Ordering Information
07-July-05	S	Update Features Update Description Update Ordering Information Update Pin Configuration Update Pin Description Update Block Diagram Update Package Outlines
28-Sept-07	S-01	Update Ordering Information
19-May-08	T	Add Example of Ordering Information Update Package Outline Drawing Add MD- to document number

NIDEC COPAL ELECTRONICS CORP. MAKES NO WARRANTY, REPRESENTATION OR GUARANTEE, EXPRESS OR IMPLIED, REGARDING THE SUITABILITY OF ITS PRODUCTS FOR ANY PARTICULAR PURPOSE, NOR THAT THE USE OF ITS PRODUCTS WILL NOT INFRINGE ITS INTELLECTUAL PROPERTY RIGHTS OR THE RIGHTS OF THIRD PARTIES WITH RESPECT TO ANY PARTICULAR USE OR APPLICATION AND SPECIFICALLY DISCLAIMS ANY AND ALL LIABILITY ARISING OUT OF ANY SUCH USE OR APPLICATION, INCLUDING BUT NOT LIMITED TO, CONSEQUENTIAL OR INCIDENTAL DAMAGES.

NIDEC COPAL ELECTRONICS CORP. products are not designed, intended, or authorized for use as components in systems intended for surgical implant into the body, or other applications intended to support or sustain life, or for any other application in which the failure of the NIDEC COPAL ELECTRONICS CORP. product could create a situation where personal injury or death may occur.

NIDEC COPAL ELECTRONICS CORP. reserves the right to make changes to or discontinue any product or service described herein without notice. Products with data sheets labeled "Advance Information" or "Preliminary" and other products described herein may not be in production or offered for sale.

NIDEC COPAL ELECTRONICS CORP. advises customers to obtain the current version of the relevant product information before placing orders. Circuit diagrams illustrate typical semiconductor applications and may not be complete.

COPAL ELECTRONICS

NIDEC COPAL ELECTRONICS CORP.
Japan Head Office
Nishi-Shinjuku, Kimuraya Bldg.,
7-5-25 Nishi-Shinjuku, Shinjuku-ku, Tokyo 160-0023
Phone: +81-3-3364-7055
Fax: +81-3-3364-7098
www.nidec-copal-electronics.com

Document No: MD-5005
Revision: T
Issue date: 05/19/2008