

PT60SRG/PT22ERG
POLYGON LASER SCANNERS

TYPICAL OUTLINE DIMENSIONS (SCANNER ASSEMBLY)

Unless otherwise specified, tolerance : ± 0.5 (Unit : mm)

PT60SRG

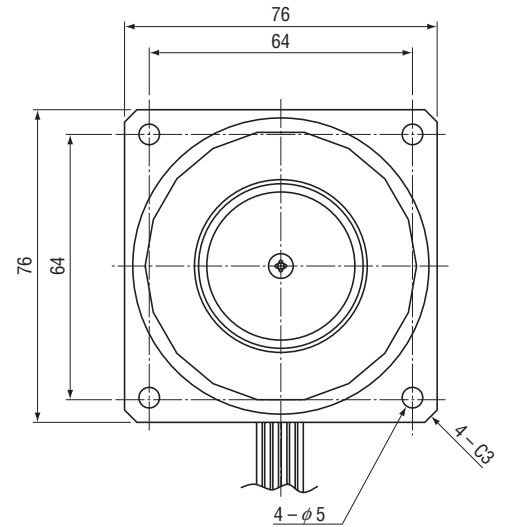
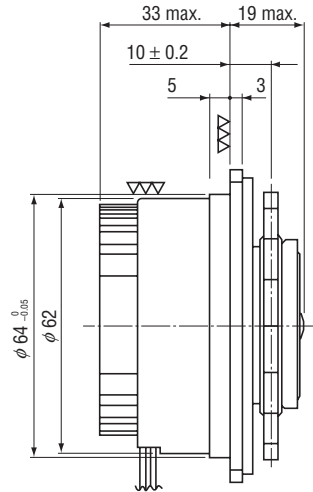

PT22ERG

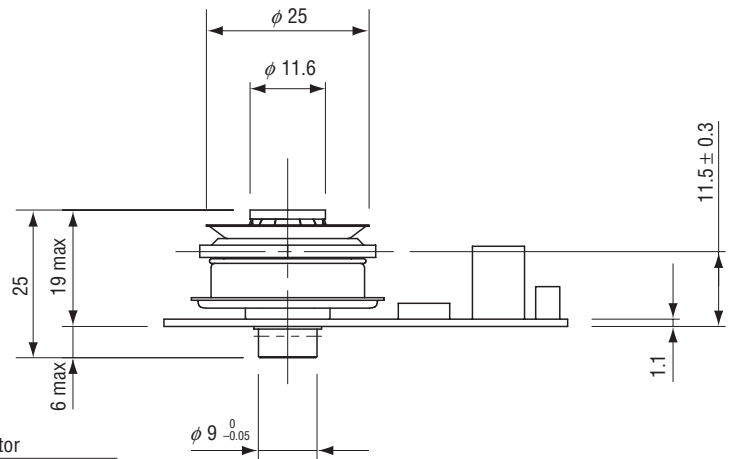
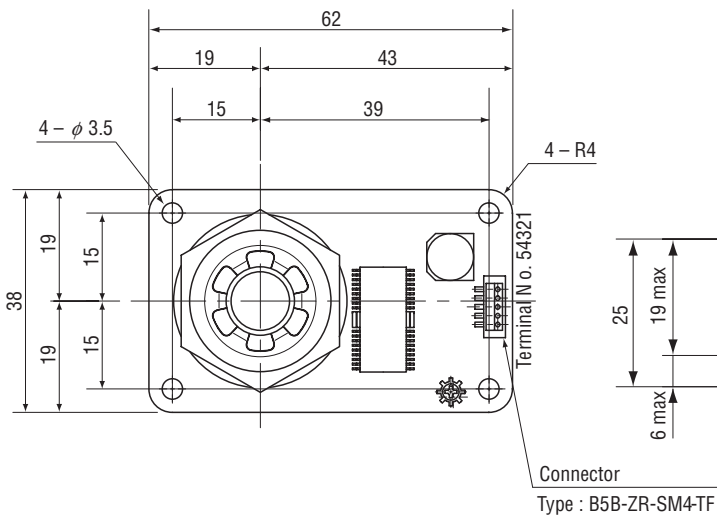

POLYGON LASER SCANNERS listed here are typical value.
 All our production will be made upon receipt of your order.
 Please contact your sales agent for details.