

STEPPING MOTORS

PLM25

FEATURES

- Stepping actuators with a built-in sensor
- Provided with connector terminals for easy connection
- World first PM stepping motors compatible with micro step drive



APPLICATIONS

- Game machines
- Indicators

PART NUMBER DESIGNATION

PLM25 - 1200

Series name

Dash number

OUTLINE DIMENSIONS

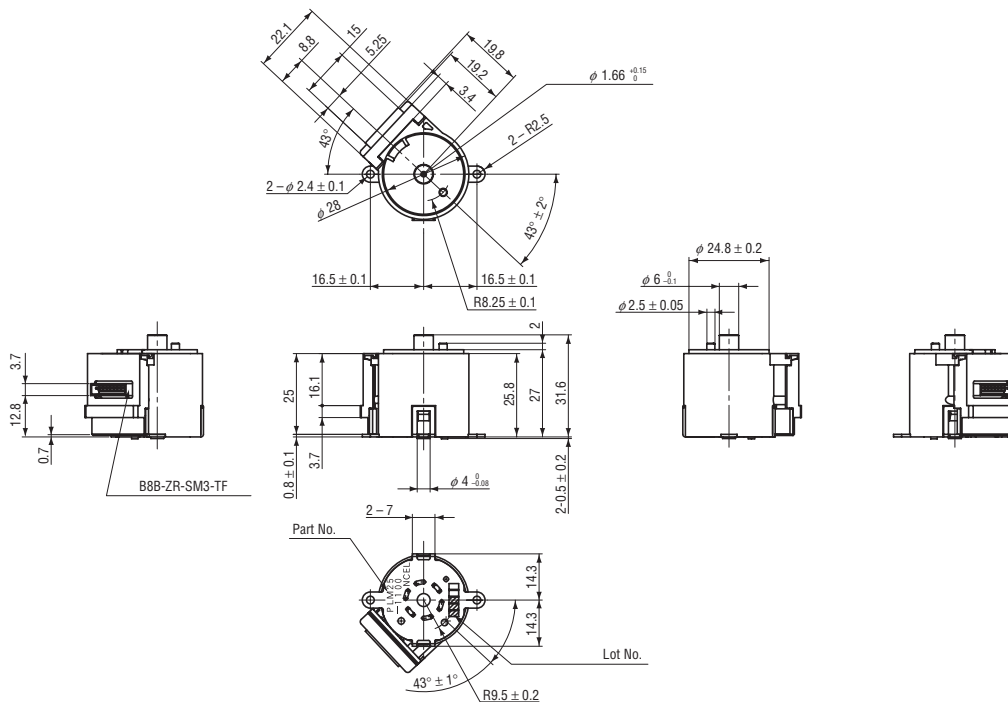

Lot production is required. Please consult us for ordering.

