

# PA-838

## PRESSURE TRANSDUCERS WITH AMP.

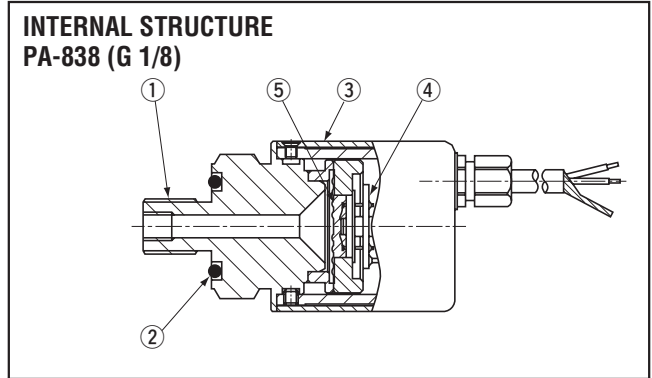

Part name	Material
① Fitting	SUS 316L
② "O" ring (P15)	Fluoro-rubber
③ Housing	Aluminum
④ Compensation resistor board	Ceramic
⑤ Sealed liquid	Silicone oil

### FEATURES

- High corrosion resistance by double diaphragm structure
- Built-in amplifier circuit
- Incorporating temperature compensation function (0 ~ 50 °C)
- Current output mode

### MODEL NUMBER DESIGNATION

PA-838-102G-05

Series name

Rated pressure range

- 501 : 0 ~ 49.0 kPa (0 ~ 0.5 kgf/cm<sup>2</sup>)
- 102 : 0 ~ 98.1 kPa (0 ~ 1 kgf/cm<sup>2</sup>)
- 103 : 0 ~ 981 kPa (0 ~ 10 kgf/cm<sup>2</sup>)

Thermal error/Fitting

- 05 : ± 0.05 % F.S./°C, G 1/8
- R2 : ± 0.05 % F.S./°C, R 1/4
- VCR : ± 0.05 % F.S./°C, VCR
- 10 : ± 0.1 % F.S./°C, G 1/8

Pressure reference

G : Gauge

### LIST OF MODEL NUMBERS

Output	Pressure reference		Gauge		
	Thermal error [% F.S./°C]	Pated pressure range kPa (kgf/cm <sup>2</sup> )	0 ~ 49.0 (0 ~ 0.5)	0 ~ 98.1 (0 ~ 1)	0 ~ 981 (0 ~ 10)
Current output	± 0.05	継手 Fitting : G 1/8	PA-838-501G-05	PA-838-102G-05	PA-838-103G-05
		継手 Fitting : R 1/4	PA-838-501G-R2	PA-838-102G-R2	PA-838-103G-R2
		継手 Fitting : VCR	PA-838-501G-VCR	PA-838-102G-VCR	PA-838-103G-VCR
	± 0.10	継手 Fitting : G 1/8	PA-838-501G-10	PA-838-102G-10	PA-838-103G-10

※ Verify the above model numbers when placing orders.

※VCR® is a registered trade name of Cajon Co. CAJON® is a registered trade name of Swagelok Co.

Note: For handling of VCR fittings, please contact a service center of Swagelok Co.

**PA-838**  
**PRESSURE TRANSDUCERS WITH AMP.**

**STANDARD SPECIFICATIONS**

● Unless otherwise specified, the specs are defined at an ambient temperature of 25±5 °C, excitation voltage of 24 V DC and load resistance of 250 Ω.

Item	Model number	PA-838			
		501G	102G	103G	
General specifications	Pressure reference	Gauge			
	Rated pressure range	kPa {kgf/cm <sup>2</sup> }	49.0 {0.5}	98.1 {1}	981 {10}
	Maximum pressure	kPa {kgf/cm <sup>2</sup> }	98.1 {1}	196 {2}	1961 {20}
	Break-down pressure	kPa {kgf/cm <sup>2</sup> }	147 {1.5}	294 {3}	2942 {30}
	Operating temp. range	°C	- 20 ~ 70		
	Compensated temp. range	°C	0 ~ 50		
	Operating humidity	%RH	35 ~ 85 (No condensation)		
	Storage temp.	°C	- 20 ~ 70 (Atmospheric pressure, humidity 65 %RH maximum)		
	Pressure medium		Corrosive gases/liquids compatible with SUS 316L ※1		
	Insulation resistance	MΩ minimum	100 (500 V DC)		
	Dielectric strength		500 V AC, 60 s (Leakage current 1 mA maximum)		
	Sealed liquid		Silicone oil		
	Pressure port		G 1/8 (PF 1/8), R1/4 (PT 1/4), 1/4 VCR® ※2		
	Net weight	g	Approx. 140		
Power	Supply voltage	V DC	24 ± 10 %		
	Ripple content	maximum	10 % (P-P)		
Analog output	Output current	mA	4 ~ 20		
	Zero current	mA	4 ± 0.2 (at 25 °C)		
	Span current	mA	16 ± 0.2 (at 25 °C)		
	Load resistance		0 ~ 500 Ω		
	Linearity/Hysteresis	%F.S.	± 0.5		
	Thermal error 0 ~ 50 °C (Reference temp.: 25 °C)	ZERO %F.S./°C	± 0.05/± 0.1		
		SPAN %F.S./°C	± 0.05/± 0.1		
	Response	ms	Approx. 2		
Gravitational effect (From vertical position to horizontal position)	%F.S. max.	Approx. 0.5	Approx. 0.3	Approx. 0.05	

※1 In case of VCR type, corrosive gases/liquids compatible with SUS 316L and SUS 316.

※2 An "O" ring provided for G1/8 type. (Positive pressure : P15)

**ENVIRONMENTAL CHARACTERISTICS**

Test item	Test conditions (At 25 ± 5 °C)	Permissible change
Vibration	10 ~ 500 Hz, 1.5 mm maximum/98.1 m/s <sup>2</sup> , 3 directions for 2 hours each	Zero current, Span current: ± 1 %F.S. maximum each
Shock	490 m/s <sup>2</sup> , 3 directions for 3 times each	
Pressure cycling	0 ~ Rated pressure, 10 <sup>6</sup> cycles	
Moisture resistance	40 °C, 90 ~ 95 %RH, 240 hrs.	

# PA-838 PRESSURE TRANSDUCERS WITH AMP.

## OUTLINE DIMENSIONS

Unless otherwise specified, tolerance : ± 0.5 (Unit: mm)

### ● G1/8 type

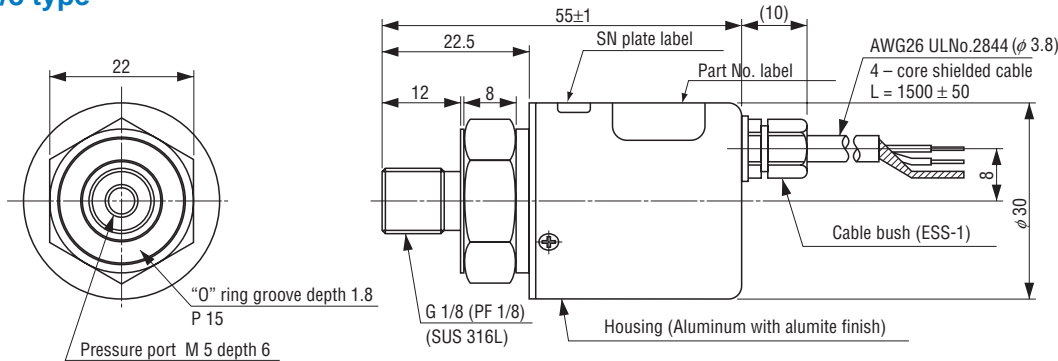

### PA-838

Wire color	Connection
Red	Power ⊕
White	Output
Shield	Fitting
Green	N.C.
Black	N.C.

### ● R1/4 type

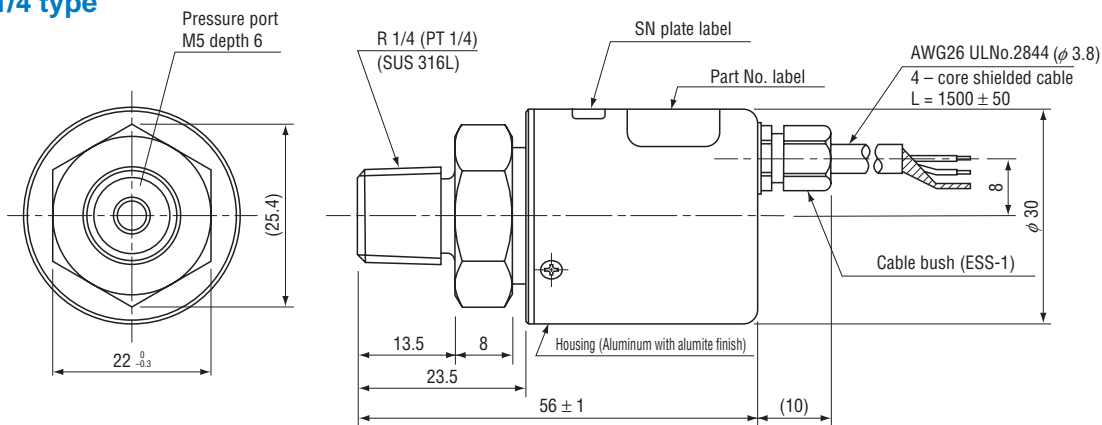

### ● VCR type

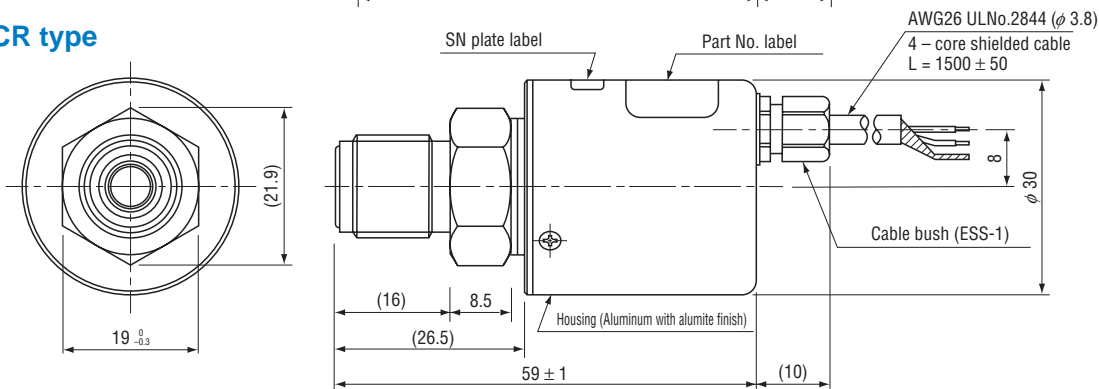

## INTERNAL ELECTRICAL SCHEMATICS

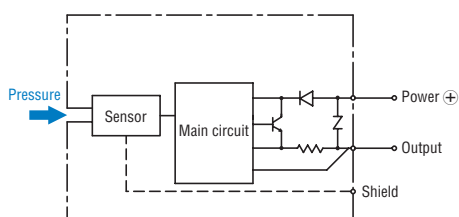

## RECOMMENDED EXTERNAL SCHEMATICS

