



**LIST OF MODEL NUMBERS**

Pressure medium	Fitting	Switch output interface	Pressure reference	Gauge		
			Rated pressure range	-10 ~ 10 kPa	-100 ~ 100 kPa	-100 ~ 1000 kPa
Non-corrosive gases	Rc 1/8		NPN	PG-30-101R-N	PG-30-102R-N	PG-30-103R-N
			PNP	PG-30-101R-P	PG-30-102R-P	PG-30-103R-P

※Verify the above model numbers when placing orders.

**ACCESSORIES (Sold separately)**

Name	Series name	Contents	Applicable model
Rear panel bracket set	ACPG-001	Rear panel bracket and M 3 × 4 male screw (2pcs.)	PG-30
Panel bracket set	ACPG-002	Panel bracket and M 3 × 4 male screw (2pcs.)	PG-30
Panel holder set	ACPG-003	Panel holder cover Panel holder Panel stopper (2pcs.)	PG-30 · PG-35 · PG-35H · PG-35L
Holder cover set (For protecting gauge operating panel)	ACPG-004	Panel holder cover Panel holder	PG-30 · PG-35 · PG-35H · PG-35L

**STANDARD SPECIFICATIONS**

● Unless otherwise specified, the specs are defined at an ambient temperature of 25±5 °C and excitation voltage of 12 V DC.

Item	Model number	PG-30			
		101R	102R	103R	
General specifications	Pressure reference	Gauge			
	Pressure medium	Non-corrosive gases			
	Rated pressure range	kPa	-10 ~ 10	-100 ~ 100	-100 ~ 1000
	Maximum pressure	kPa	20	200	1500
	Break-down pressure	kPa	50	500	2000
	Operating temp. range	°C	-10 ~ 50		
	Compensated temp. range	°C	0 ~ 50		
	Operating humidity	%RH	35 ~ 85		
	Protection grade		In accordance with IEC IP-65		
	Pressure port		2-Rc 1/8		
	Material of pressure port attachment		Aluminum die-casting, silicone		
	Net weight	g	Approx. 80 (Including 2 m cable)		
	Thermal error		±3 %F.S. (0 ~ 50 °C)		
	Insulation resistance		100 MΩ以上 100 MΩ minimum (DC500 V)		
	Dielectric strength		AC500 V 1 minute (Leakage current 1 mA maximum)		
	Input voltage		10.8 ~ 30 V DC (Including ripple percentage)		
Consumption current		50 mA maximum			

**STANDARD SPECIFICATIONS**

● Unless otherwise specified, the specs are defined at an ambient temperature of  $25 \pm 5 \text{ }^\circ\text{C}$  and excitation voltage of 12 V DC.

Item		Model number	PG-30		
			101R	102R	103R
Display	Display element		Full 3-digit LED		
	Rated display range	kPa	- 9.99 ~ 9.99	- 99.9 ~ 99.9	- 100 ~ 999
	Multiplier settings		Max. 11 settings		
	Negative pressure display		Red LED is ON.		
	Display accuracy		$\pm 1 \%$		
Switch output	Output status		NPN/PNP 2-point output (Transistor, Open collector output)		
	Output mode		Separate mode / window comparator mode		
	Switching capacity		30 V DC 100 mA Short-circuit protection		
	Residual voltage		1.2 V maximum (NPN), 2.2 V maximum (PNP) (At load current of 100 mA)		
	State indication		Output 1 (Green LED), Output 2 (Red LED) Lighted when output is ON.		
	Switch hysteresis		0 ~ 300 counts (Adjustable)		
	Repeatability		$\pm 0.2 \%$ F.S. $\pm 1$ count ( $\pm 0.3 \%$ F.S. maximum)		
	Response		Approx. 5, 25, 250, 2500 ms Adjustable		
Analog output	出力モード Output mode		3 modes		
	Output voltage V zero : Pin=0, V span : Pin=0~Pin (H)		1 ~ 5 V (G/V mode ZERO : $1 \pm 0.2$ V, SPAN : $4 \pm 0.2$ V) R mode ZERO : $3 \pm 0.2$ V, SPAN : $2 \pm 0.2$ V)	103 R (R mode)	ZERO : $1.36 \pm 0.2$ V SPAN : $3.64 \pm 0.2$ V
	Impedance		10 k $\Omega$		
	Resolution		1/204		
	Response		Approx. 5, 25, 250, 2500 ms Adjustable		
<b>Accessories</b>			Seal screw, M 5 connecting joint screw		

**ENVIRONMENTAL CHARACTERISTICS**

Test item	Test conditions	Permissible change
Vibration	10 ~ 500 Hz, 98.1 m/s <sup>2</sup> or 1.5 mm P-P, 3 directions for 2 hours each	$\pm 2 \%$ F.S. maximum after test ※1 [ Amount of analog output fluctuation is permitted by adding conversion error of 20 mV. ]
Shock	490 m/s <sup>2</sup> , 3 directions for 3 times each	
Pressure cycling	0 ~ Rated pressure、10 <sup>6</sup> cycles	
Moisture resistance	40 $^\circ\text{C}$ , 90 ~ 95 %RH, 240 hrs.	
EMC	EMI : EN55011: 2007, A2 : 2007 Group 1, class B EMS : EN61326-1 : 2006 Table 2	Pressure indication, switch operating pressure and analog output : $\pm 5 \%$ F.S. maximum during test ※1

※1 Change in the pressure indication, switch operating points and analog output.

**INTERNAL ELECTRICAL SCHEMATICS**

● NPN

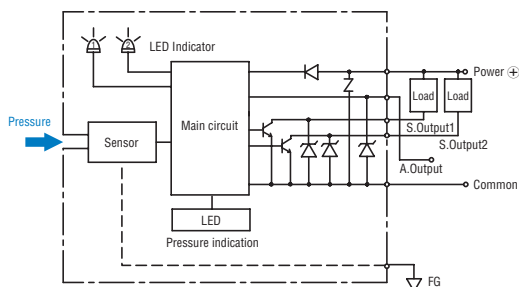

● PNP

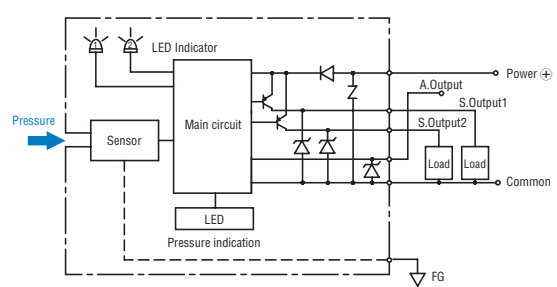

## SELECTION OF DISPLAY MULTIPLIER

The last digit/letter represents the selection code : Blinking red LED indicates negative pressure.

Display multiplier	Pressure range (-Pr ~ +Pr)		
	101R	102R	103R
1 × 1	- 9.99 ~ 9.99	- 99.9 ~ 99.9	- 100 ~ 999
2 × 0.0102			- 1.02 ~ 9.99
3 × 10.2	- 99.9 ~ 99.9	- 999 ~ 999	
4 × 7.501	- 75.0 ~ 75.0	- 750 ~ 750	
5 × 102	- 999 ~ 999		
6 × 0.01			- 1.00 ~ 9.99
7 × 10	- 99.9 ~ 99.9	- 999 ~ 999	
8 × 0.145	- 1.45 ~ 1.45	- 14.5 ~ 14.5	- 14 ~ 145
9 × 0.000145			
A × 0.001			- 0.10 ~ 1.00
b × 0.2953	- 2.95 ~ 2.95	- 29.5 ~ 29.5	- 29 ~ 295

Diagonal column: Display multiplier cannot be selected due to resolution and number of digits. (Selection code is not indicated either.) Selection code is set at "1" prior to shipment.

## ANALOG OUTPUT MODE

Display	Pressure range	Pressure range (-Pr ~ 0 ~ Pr)		
		-Pr	0	Pr
1	R mode	1 V	----->	5 V
2	G mode		1 V	----->
3	V mode	5 V	----->	1 V

When shipped from our factory-101R : R mode is set at "1", 102R : V mode is set at "3" and 103R : G mode is set at "2". The above 3 types can be set at "1", "2" or "3". However, the accuracy at V mode of 103R can't be guaranteed.

## SWITCH OUTPUT MODE

Output	SW1				SW2			
	Separate		Window comparator		Separate		Window comparator	
Mode	HI	LO	A	B	HI	LO	A	B
1	○				○			
2	○				○	○		
3		○				○		
4		○				○		
5			○				○	
6			○				○	
7				○				○
8				○				○
Pressure setting (Operating point)	Setting 1		(Lower limit) : Setting 1 (Upper limit) : Setting 2		Setting 2		(Lower limit) : Setting 1 (Upper limit) : Setting 2	

Note 1. In the Separate Mode, setting 1 corresponds to SW1, and Setting 2 corresponds to SW2.

Note 2. In the Window Comparator Mode, the minimum value for SW1 and SW2 corresponds to Setting 1 and the maximum value corresponds to Setting 2.

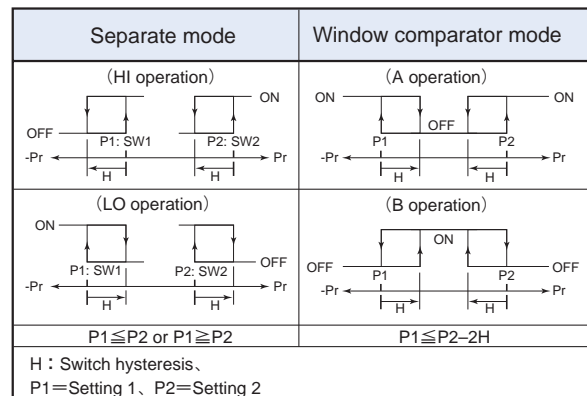

## PG-30 PRESSURE GAUGES

### OUTLINE DIMENSIONS

#### PG-30

Unless otherwise specified tolerance :  $\pm 0.5$  (Unit: mm)

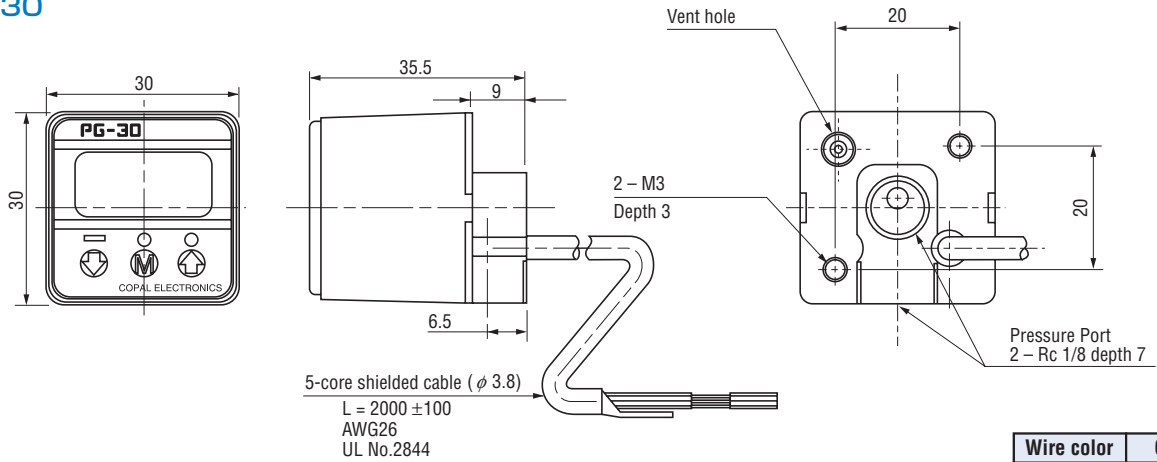

Wire color	Connection
Brown	Power $\oplus$
Gray	Analog output
Black	Switch output 1
White	Switch output 2
Blue	Common
Shield	Fitting

### HOW TO MOUNT OPTIONAL ACCESSORIES (Sold separately)

(Unit: mm)

#### PG-30 Rear panel mounting bracket

#### PG-30 Panel mounting bracket

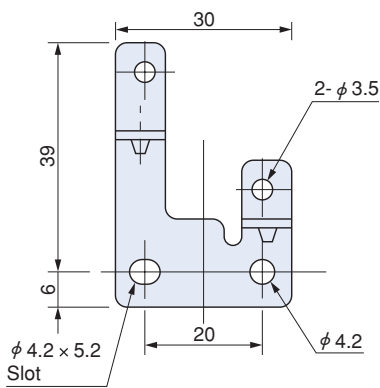

Material : SUS304  
t = 1.5

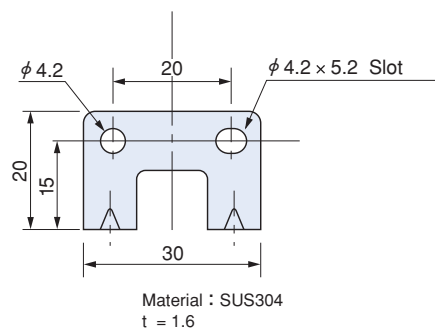
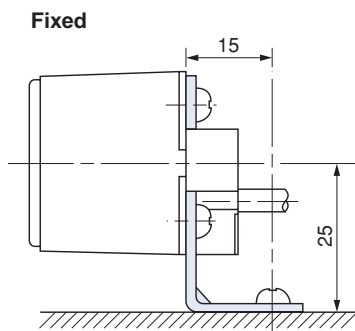
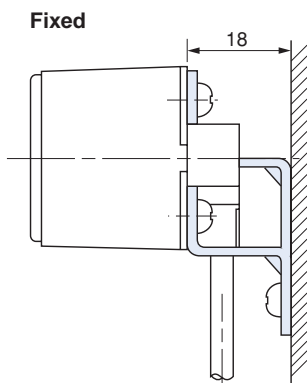
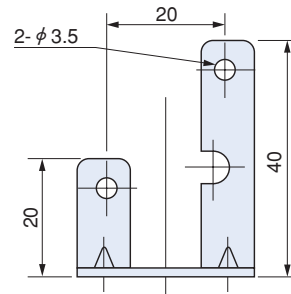
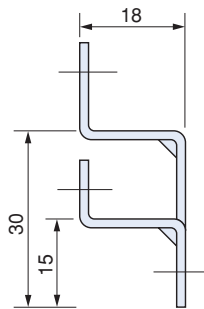

Material : SUS304  
t = 1.6

## PG-30 PRESSURE GAUGES

### ■ HOW TO MOUNT OPTIONAL ACCESSORIES (Sold separately)

(Unit: mm)

#### ● PG-30 • PG-35 • PG-35H • PG-35L Panel cut holder set & holder cover set

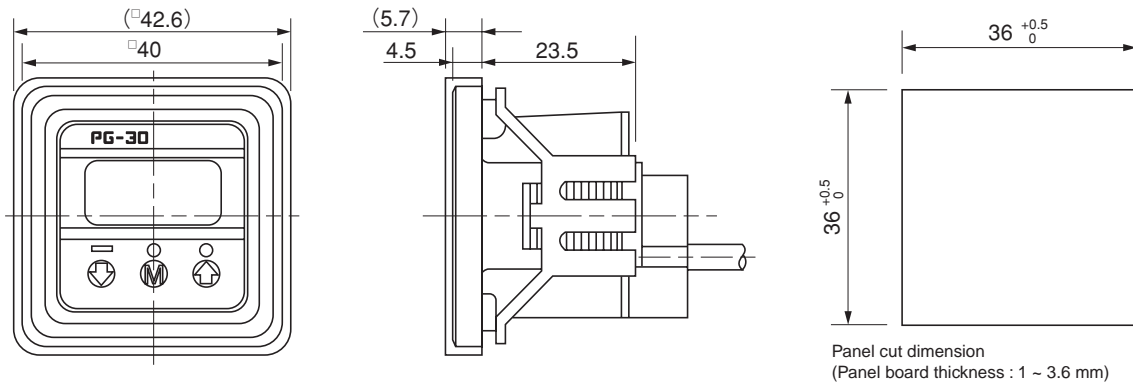

#### ● Panel holder cover set

