

# PS6

## PRESSURE SWITCHES WITH GAUGE

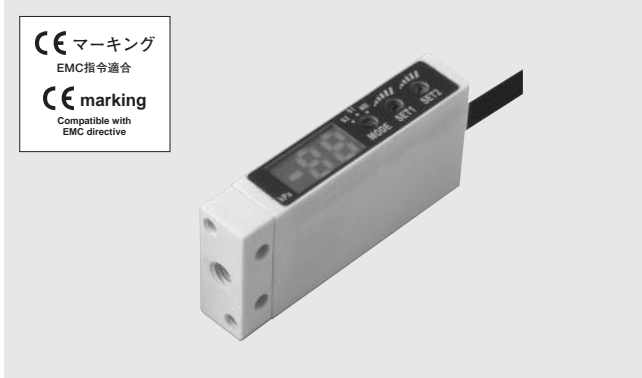

### FEATURES

- Solidstate pressure switch with no mechanical moving parts
- 2 types of pressure ports are available
- Open collector output of either NPN or PNP is available
- Analog output type available

### INTERNAL STRUCTURE (M5 female screw)

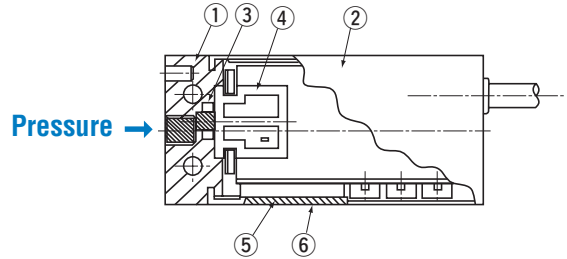

	Part name	Material
①	Pressure port	POM (Polyoxymethylene)
②	Housing	PC (Polycarbonate)
③	“O” ring	Fluoro-rubber
④	Sensor module board	—
⑤	Protection panel	PET (Polyethyleneterephthalate)
⑥	Main panel	

### MODEL NUMBER DESIGNATION

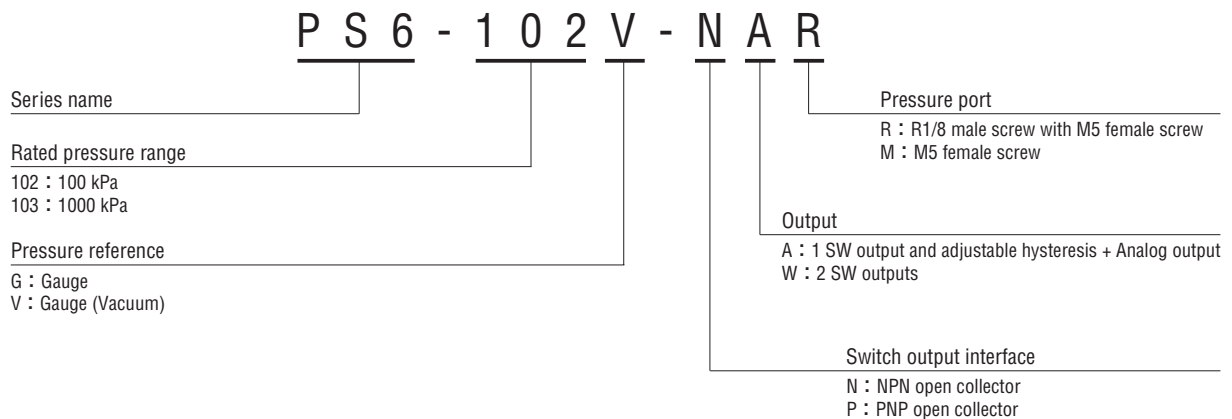

### LIST OF MODEL NUMBERS

Pressure port	Outputs	Switch output	102V	102G	103G
			0 ~ 100 kPa	0 ~ 100 kPa	0 ~ 1000 kPa
R 1/8 male screw	Adjustable hysteresis switch output + Analog output	NPN open collector output	PS6-102V-NAR	PS6-102G-NAR	PS6-103G-NAR
		PNP open collector output	PS6-102V-PAR	PS6-102G-PAR	PS6-103G-PAR
	Switch outputs (2 points)	NPN open collector output	PS6-102V-NWR	PS6-102G-NWR	PS6-103G-NWR
		PNP open collector output	PS6-102V-PWR	PS6-102G-PWR	PS6-103G-PWR
M 5 female screw	Adjustable hysteresis switch output + Analog output	NPN open collector output	PS6-102V-NAM	PS6-102G-NAM	PS6-103G-NAM
		PNP open collector output	PS6-102V-PAM	PS6-102G-PAM	PS6-103G-PAM
	Switch outputs (2 points)	NPN open collector output	PS6-102V-NWM	PS6-102G-NWM	PS6-103G-NWM
		PNP open collector output	PS6-102V-PWM	PS6-102G-PWM	PS6-103G-PWM

※Verify the above model numbers when placing orders.

**PS6**  
**PRESSURE SWITCHES WITH GAUGE**

**STANDARD SPECIFICATIONS**

● Unless otherwise specified, the specs are defined at an ambient temperature of 25 ± 5 °C and excitation voltage of 12 V DC.

Item	Model number	PS6			
		102V	102G	103G	
General specifications	Pressure reference	Gauge			
	Rated pressure range	kPa	0 ~ -100	0 ~ 100	0 ~ 1000
	Maximum pressure	kPa	200	200	1500
	Break-down pressure	kPa	500	500	2000
	Operating temp. range	°C	-10 ~ 60		
	Compensated temp. range	°C	0 ~ 50		
	Operating humidity	%RH	35 ~ 85 (No condensation)		
	Storage temp.	°C	-20 ~ 70 (Atmospheric pressure, humidity 65 %RH maximum)		
	Pressure medium		Non-corrosive gases		
	Insulation resistance	MΩ min.	100 (500 V DC)		
	Dielectric strength		500 V AC, 60 s (Leakage current 1 mA maximum)		
	Pressure port		R 1/8 (Female screw) or M5		
	Net weight	g	Approx. 50 (Including cable)		
Power	Supply voltage	V DC	12 ~ 24 V ± 10 % (Including ripple percentage)		
	Consumption current	mA max.	35		
Display	Display element		2-digit LED		
	Rated display range		-0 ~ -99 kPa	0 ~ 99 kPa	.0 ~ .99 MPa
	Display accuracy 0~50°C (Reference temp. 25 °C)		± 3 %F.S.		
	Resolution		1 count		
Switch output	No. of outputs		1 or 2		
	Output interface		Open collector output (NPN or PNP)		
	Setting method		Adjustable by VR	※1	
	Adjustable range		0 ~ 100 of rated pressure	※2	
	Display		Red LED ON (W type only : SW1 Red, SW2 Green)		
	Accuracy 0~50°C (Reference temp. 25 °C)	%F.S.	± 3		
	Switch hysteresis		Approx. 0 ~ 15 % of the set value (W type only 2 % F.S. maximum)		
	Switching capacity		30 V 80 mA maximum		
	Residual voltage	V maximum	0.8 (NPN), 1.2 (PNP)		
Response	ms	Approx. 2			
Analog output	Output voltage	V	1 ~ 5		
	Zero voltage	V	1 ± 0.1		
	Span voltage	V	4 ± 0.1		
	Output current	mA maximum	1 (Load resistance 5 kΩ minimum)		

※1 : Please set adjusting torque at 30 mN·m maximum.

※2 : The actual setting range adjustable by VR has a little overrunning margin beyond the rated display of 0 through 99. This could cause the setting value of VR may be under "0" or over "99".

# PS6 PRESSURE SWITCHES WITH GAUGE

## ENVIRONMENTAL CHARACTERISTICS

Test item	Test conditions	Permissible change
Vibration	10 ~ 500 Hz, 1.5 mm maximum/98.1 m/s <sup>2</sup> , 3 directions for 2 hours each	Pressure indication, switch operating pressure and analog output variation : ± 2 %F.S., maximum each after test
Shock	196 m/s <sup>2</sup> , 3 directions for 3 times each	
Moisture resistance	40 °C, 90 ~ 95 %RH, 240 hrs.	
Pressure cycling	0 ~ Rated pressure, 10 <sup>6</sup> cycles	
EMC	EMI : EN55011: 2007, A2 : 2007 Group 1, class B EMS : EN61326-1 : 2006 Table 2	Pressure indication, switch operating pressure and analog output variation : ± 5 %F.S., maximum during test

## CIRCUIT DIAGRAMS

- NAM, NAR (NPN)
- NAN, NAR (NPN/Adjustable hysteresis switch)

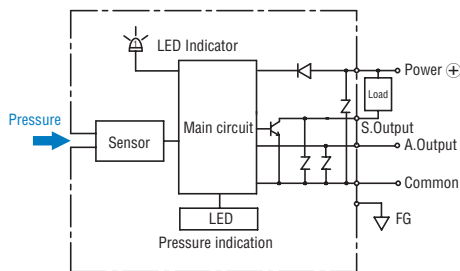

- PAM, PAR (PNP)
- PAN, PAR (PNP/Adjustable hysteresis switch)

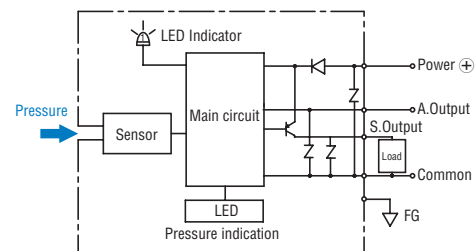

- NWM, NWR (NPN)
- NWN, NWR (NPN/2 switch outputs)

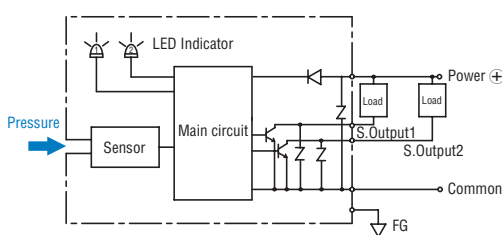

- PWM, PWR (PNP)
- PWN, PWR (PNP/2 switch outputs)

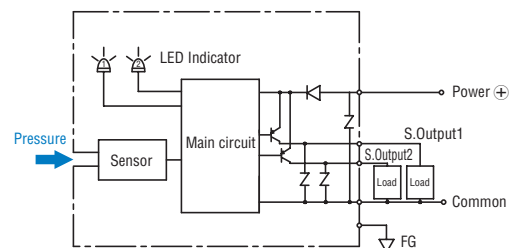

## SWITCHING OPERATION

- The switch turns on at the set pressure and turns off at the set pressure minus the hysteresis.

### ● PS6-102V

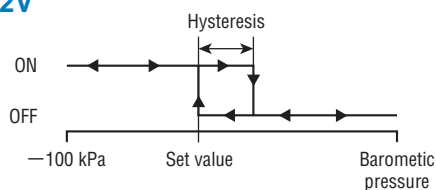

### ● PS6-\*\*\*G

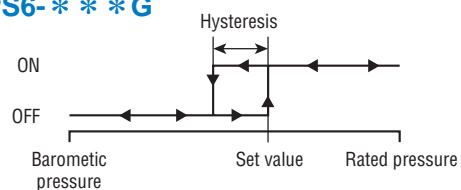

※ \*A\* is adjustable hysteresis type.

# PS6 PRESSURE SWITCHES WITH GAUGE

## OUTLINE DIMENSIONS

Unless otherwise specified, tolerance : ± 0.5 (Unit: mm)

### (NAR, PAR, NWR, PWR)

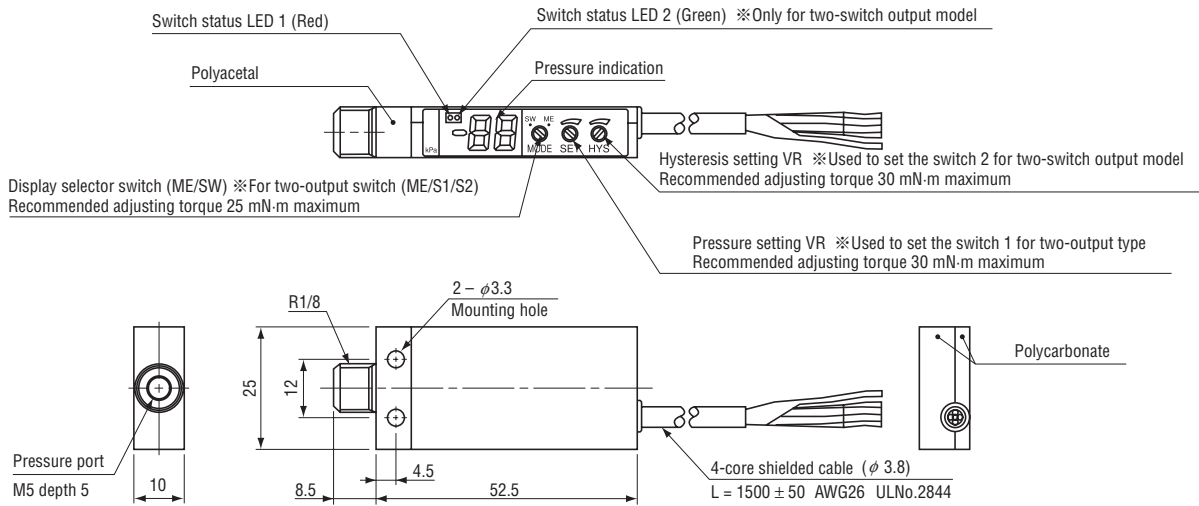

### (NAM, PAM, NWM, PWM)

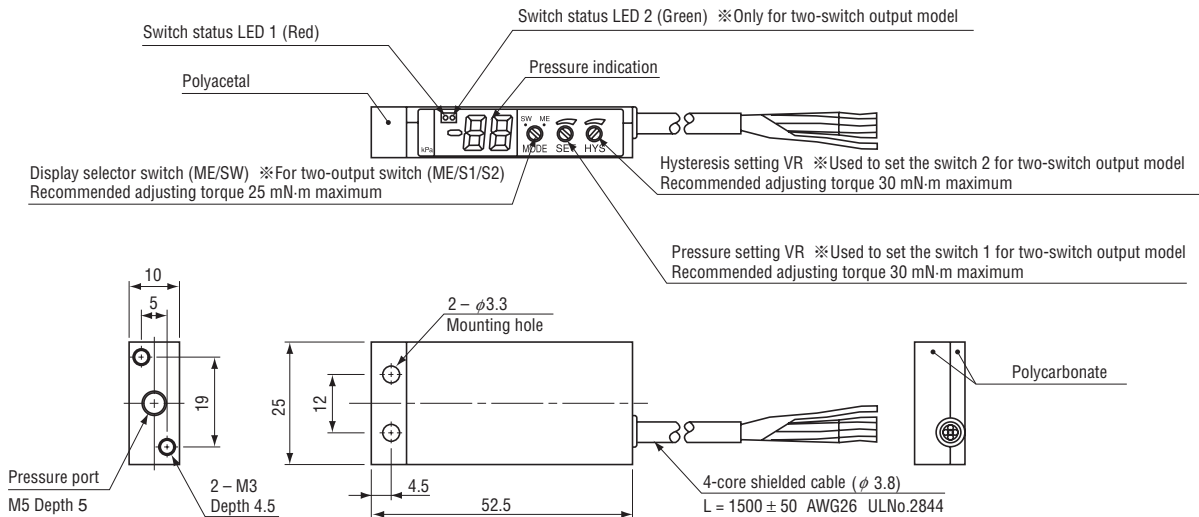

#### PS6 (NAM, NAR, PAM, PAR)

Wire color	Connection
Brown	Power ⊕
Black	Switch output
White	Analog output
Blue	Common
Shield	N.C.

#### PS6 (NWM, NWR, PWM, PWR)

Wire color	Connection
Brown	Power ⊕
Black	Switch output 1
White	Switch output 2
Blue	Common
Shield	N.C.