

# PS83

## PRESSURE SWITCHES



### FEATURES

- Solidstate pressure switch with no mechanical moving parts
- High corrosion resistance by double diaphragm structure
- Two pressure setting points
- Wide pressure medium compatibility
- Can be attached with a ※VCR® fitting

**INTERNAL STRUCTURE (G 1/8)**

Part name	Material
① Fitting	SUS 316L
② "O" ring (P15 or P12.5)	Fluoro-rubber
③ Housing	Aluminum
④ Compensation resistor board	Ceramic
⑤ Sealed liquid	Silicone oil

### MODEL NUMBER DESIGNATION

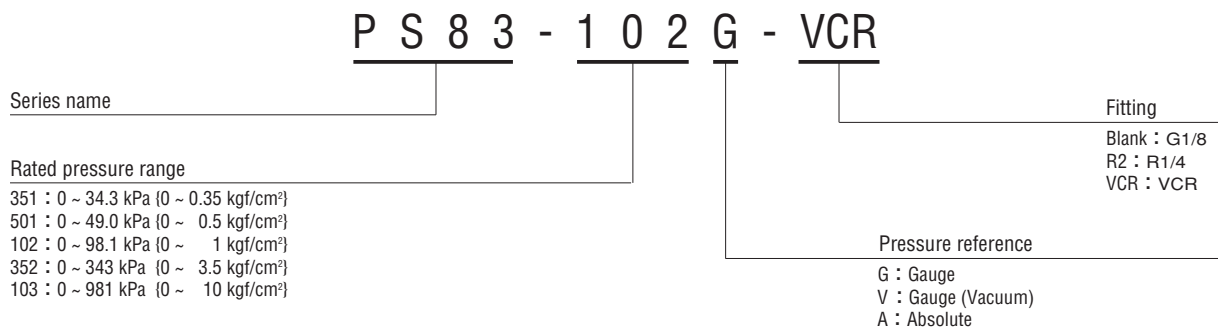

※Please refer to the LIST OF MODEL NUMBERS when placing orders.

※VCR® is a registered trade name of Cajon Co. CAJON® is a registered trade name of Swagelok Co.

Note: For handling of VCR fittings, please contact a service center of Swagelok Co.

**LIST OF MODEL NUMBERS**

Pressure reference		Gauge					Absolute	
Pressure port	Rated pressure range kPa (kgf/cm <sup>2</sup> )	0 ~ 49.0 {0 ~ 0.5}	0 ~ 98.1 {0 ~ 1}	0 ~ 343 {0 ~ 3.5}	0 ~ 981 {0 ~ 10}	0 ~ -98.1 {0 ~ -1}	0 ~ 34.3 {0 ~ 0.35}	0 ~ 98.1 {0 ~ 1}
G 1/8 (PF 1/8)		PS83-501G	PS83-102G	PS83-352G	PS83-103G	PS83-102V	PS83-351A	PS83-102A
R 1/4 (PT 1/4)		PS83-501G-R2	PS83-102G-R2	PS83-352G-R2	PS83-103G-R2	PS83-102V-R2	PS83-351A-R2	PS83-102A-R2
VCR(9/16-18UNF)		PS83-501G-VCR	PS83-102G-VCR	PS83-352G-VCR	PS83-103G-VCR	PS83-102V-VCR	PS83-351A-VCR	PS83-102A-VCR

※ Verify the above model numbers when placing orders.

**STANDARD SPECIFICATIONS**

● Unless otherwise specified, the specs are defined at an ambient temperature of 25 ± 5 °C and excitation voltage of 12 V DC.

Item	Model number	PS83							
		501G	102G	102V	352G	103G	351A	102A	
General specifications	Pressure reference	Gauge					Absolute		
	Rated pressure range	kPa {kgf/cm <sup>2</sup> }	49.0 {0.5}	98.1 {1}	- 98.1 {-1}	343 {3.5}	981 {10}	34.3 (abs) {0.35}	98.1 (abs) {1}
	Maximum pressure	kPa {kgf/cm <sup>2</sup> }	98.1 {1}	196 {2}		686 {7}	1961 {20}	103 (abs) {1.05}	196 (abs) {2}
	Break-down pressure	kPa {kgf/cm <sup>2</sup> }	147 {1.5}	294 {3}		1030 {10.5}	2941 {30}	147 (abs) {1.5}	294 (abs) {3}
	Operating temp. range	°C	- 20 ~ 70						
	Compensated temp. range	°C	0 ~ 50						
	Operating humidity	%RH	35 ~ 85 (No condensation)						
	Storage temp.	°C	- 20 ~ 70 (Atmospheric pressure humidity 65 %RH maximum)						
	Pressure medium		Corrosive gases/liquids compatible with SUS 316L ※1						
	Insulation resistance	MΩ minimum	100 (500 V DC)						
	Dielectric strength		500 V AC, 60 s (Leakage current 1mA maximum)						
	Sealed liquid		Silicone oil						
	Pressure port		G 1/8 (PF 1/8) ※2, R 1/4 (PT 1/4), 1/4 VCR®						
	Net weight	g	Approx. 140						
Power	Supply voltage	V DC	12 ~ 24 ± 10 %						
	Ripple content	maximum	10 % (P-P) maximum						
	Consumption current	maximum	20 mA						

※1 : Also compatible with SUS316 in case of PS83-□□□□-VCR.

※2 : In case of G 1/8 type, An "O" ring is supplied as accessory.  
(P15 for positive press., P12.5 for negative / absolute press.)

# PS83 PRESSURE SWITCHES

Item	Model number	PS83							
		501G	102G	102V	352G	103G	351A	102A	
Switch output	No. of output	2							
	Output interface	NPN open collector output							
	Setting method	Adjustable by VR							
	Adjustable range	Zero through rated pressure, minimum							
	Display	Red LED (lighted when output is ON.)							
	Accuracy 0 ~ 50 °C (Reference temp.: 25 °C)	% F.S.	± 3						
	Hysteresis	% F.S. maximum	2						
	Switching capacity	30 V DC 80 mA maximum							
	Residual voltage	V maximum	0.8						
	Response	ms	Approx. 2						

## ENVIRONMENTAL CHARACTERISTICS

Test item	Test conditions (At 25 ± 5 °C)	Permissible change
Vibration	10 ~ 500 Hz, 1.5 mm maximum/98.1 m/s <sup>2</sup> , 3 directions for 2 hours each	Switch output setting: ± 1 %F.S. maximum
Shock	490 m/s <sup>2</sup> , 3 directions for 3 times each	
Pressure cycling	0 ~ Rated pressure, 10 <sup>6</sup> cycles	
Moisture resistance	40 °C, 90 ~ 95 %RH, 240 hrs.	

## INTERNAL ELECTRICAL SCHEMATICS

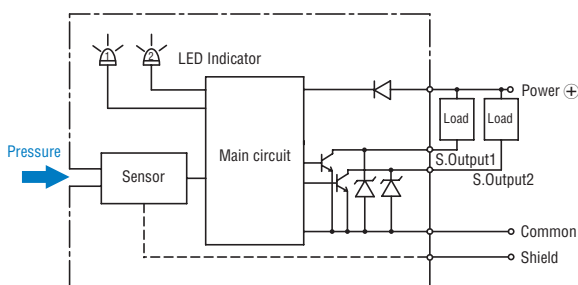

## SWITCHING OPERATION

### ● PS83-\*\*\*G

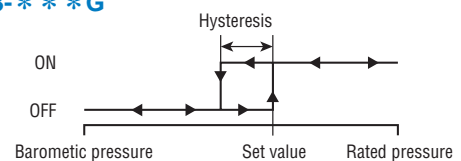

### ● PS83-102V

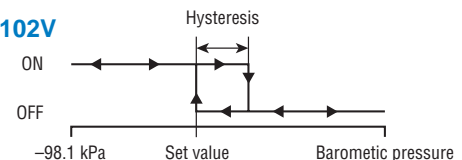

### ● PS83-\*\*\*A

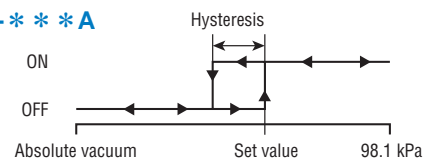

※スイッチ2点とも同一動作 2 switches show same performance.

**PS83**  
**PRESSURE SWITCHES**

**OUTLINE DIMENSIONS**

Unless otherwise specified, tolerance : ± 0.5(Unit: mm)

● PS83 (G 1/8 type)

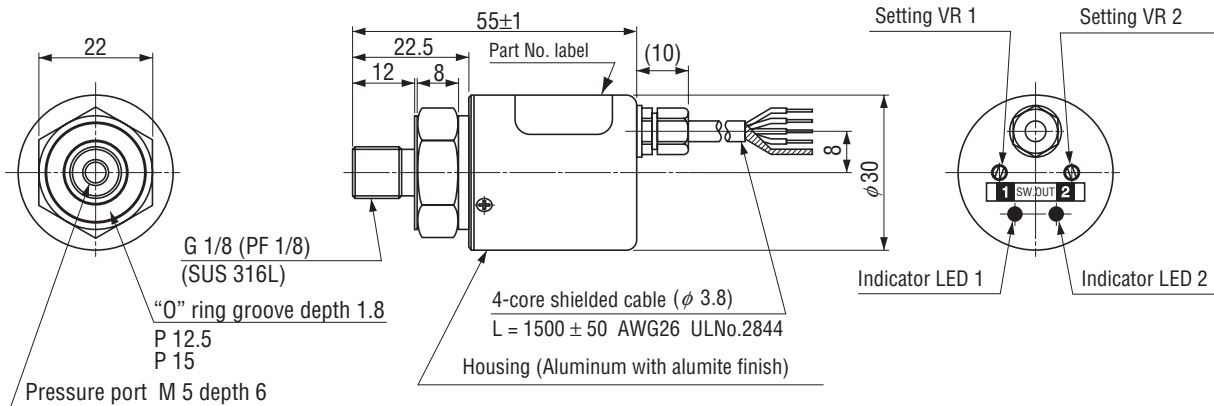

● PS83 (R1/4 type)

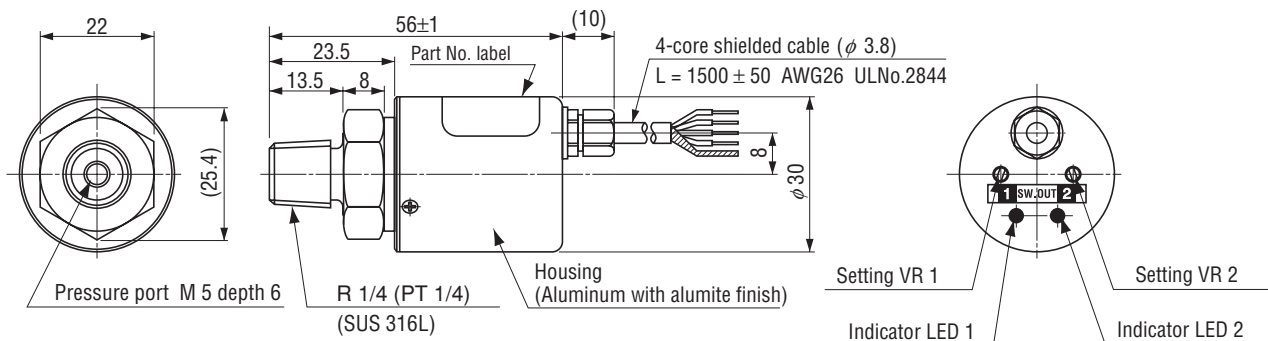

● PS83 (VCR type)

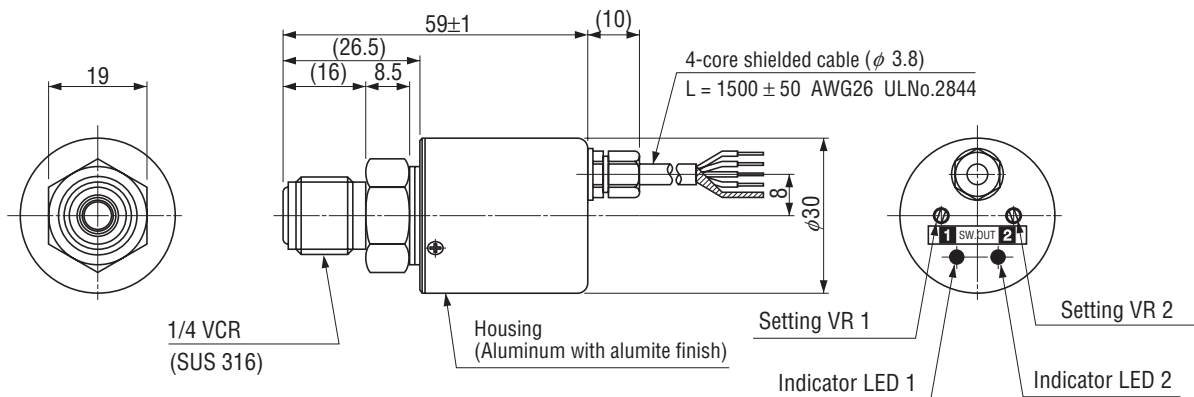

Wire color	Connection
Red	Power ⊕
Green	Output 1
White	Output 2
Black	Common
Shield	Fitting