

RE20F

OPTICAL ENCODERS

FEATURES

- Compact, dia.: 20 mm
- Low torque, low inertia
- RoHS compliant



PART NUMBER DESIGNATION

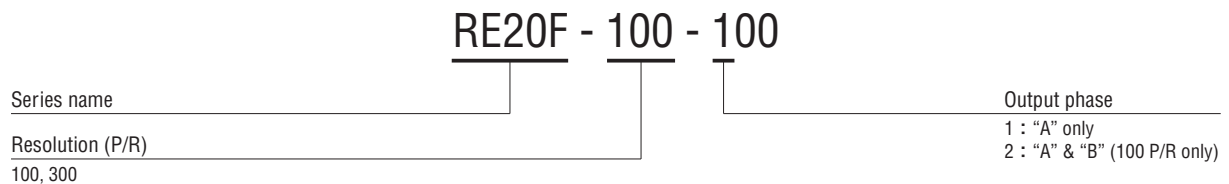

LIST OF PART NUMBERS

Resolution	Item	Output phases	Part number
100 (P/R)		"A" only	RE20F-100-100
300 (P/R)			RE20F-300-100
100 (P/R)		"A" & "B"	RE20F-100-200

※ Verify the above part numbers when placing orders.

STANDARD SPECIFICATIONS

Electrical characteristics

Item	Output phases	"A" only	"A" & "B"
Photo-sensor maximum current		45 mA maximum (at 25 °C)	
Output wave form		Quasi-sinusoidal	
Output phases		A	A, B
Resolution		100, 300	100
Phase difference of outputs A & B		—	90° ± 45°
Maximum frequency response		—	12 kHz
Output signal		150 mVp-p minimum ※1	1 Vp-p minimum
Output signal amplitude variation ※2		40 % maximum	
Light source		LED	

※1 Measured at CP1 in the fig.A of 'MEASUREMENT CIRCUIT' on the following page.

※2 One phase only : Measured at CP2 in the fig.A of 'MEASUREMENT CIRCUIT' on the following page.

Mechanical characteristics

Starting torque	0.05 mN·m {0.5 gf·cm} maximum	
Inertia	0.2 g·cm ² maximum	
Shaft loading (When mounting)	Radial	1.96 N {200 gf} maximum
	Axial	4.9 N {500 gf} maximum
Net weight	Approx. 15 g	

Environmental characteristics

Operating temp. range	0 ~ 50 °C	
Storage temp. range	- 20 ~ 80 °C	
Protection grade	IP - 40	

RELIABILITY TEST

The output wave form and starting torque shall satisfy the STANDARD SPECIFICATIONS after the following tests.

Test item		Test conditions
Vibration	Power OFF	Amplitude : 1.52 mm or 98.1 m/s ² (10 G) whichever is smaller. 10 ~ 500 Hz excursion 5 min/cycle, 1 hour each for X, Y, Z, directions.
Shock	Power OFF	1 time each in 6 directions (X, Y, Z) at 490 m/s ² (50 G), 11 ms.
High temperature exposure	Power OFF	80 °C 96 h
	Power ON	50 °C 96 h
Low temperature exposure	Power OFF	- 20 °C 96 h
	Power ON	0 °C 96 h
Humidity	Power OFF	(To be measured after wiping out moisture and leaving samples for 1 h at normal temperature and humidity after the test.)
Thermal shock	Power OFF	To be done 10 cycles with the following condition (To be measured after leaving samples for 1 h at normal temperature and humidity after the test.) 70 °C 1 h, - 20 °C 1 h

OUTLINE DIMENSIONS

Unless otherwise specified, tolerance: ± 0.4 (Unit: mm)

● RE20F

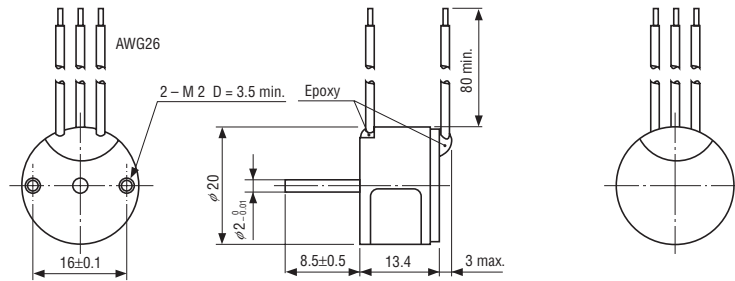

OUTPUT

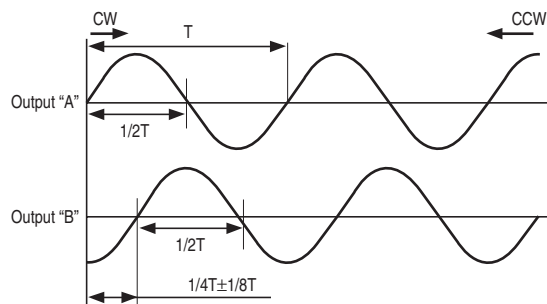

RE20F OPTICAL ENCODERS

EXTERNAL SCHEMATICS

● (2 phase) 100 P/R

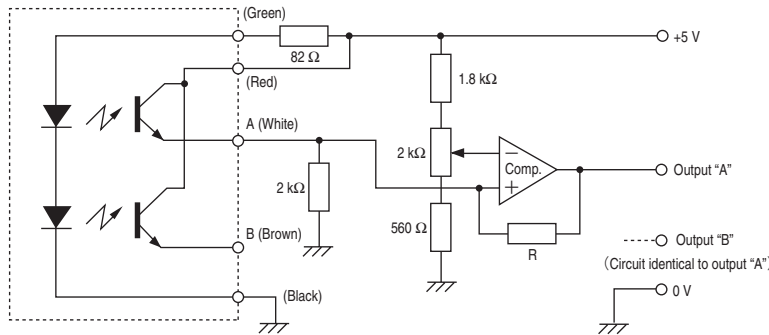

INTERNAL CIRCUIT

● (1 phase) 100 • 300 P/R

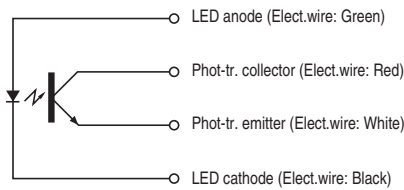

● (2 phases) 100 P/R

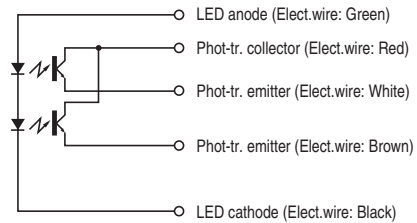

MEASUREMENT CIRCUIT

● (1 phase) 100 • 300 P/R

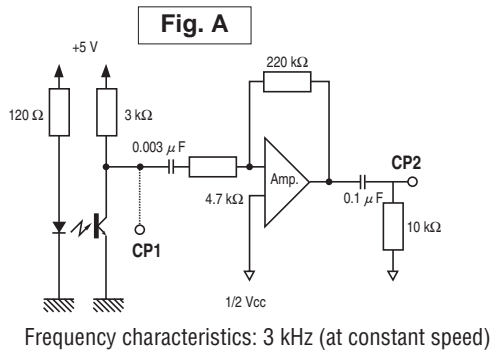

● (2 phases) 100 P/R

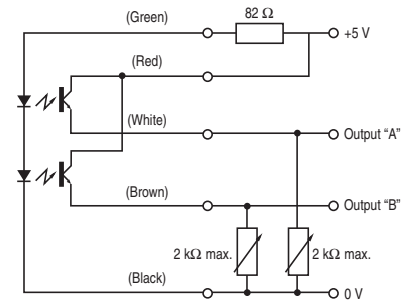

Please consult us for position control applications.

RATINGS

● LED

(at 25 °C)

Maximum current	45 mA
Reverse voltage	4 V
Power dissipation (P _D)	75 mW
Temp. derating of P _D (25 ~ 60 °C)	-1.4 mW/°C

● Photo-sensor

(at 25 °C)

Collector current	20 mA
Collector to emitter voltage (forward)	20 V
Collector to emitter voltage (reverse)	5 V
Collector dissipation (P _D)	75 mW
Temp. derating of P _D (25 ~ 60 °C)	-1.0 mW/°C